

**TCORX**  
PROFESSIONAL LINE

# MANUALE D'ISTRUZIONI

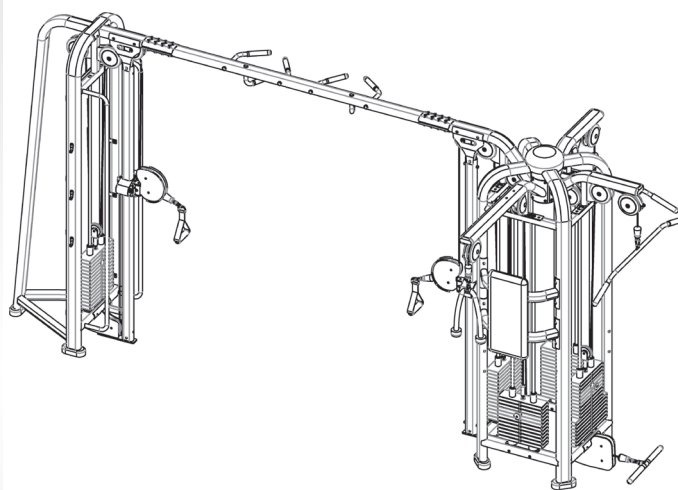

**CSX9100**



Cod : GRLDTCORXCSX9100

Rev : 00

Ed : 03/25

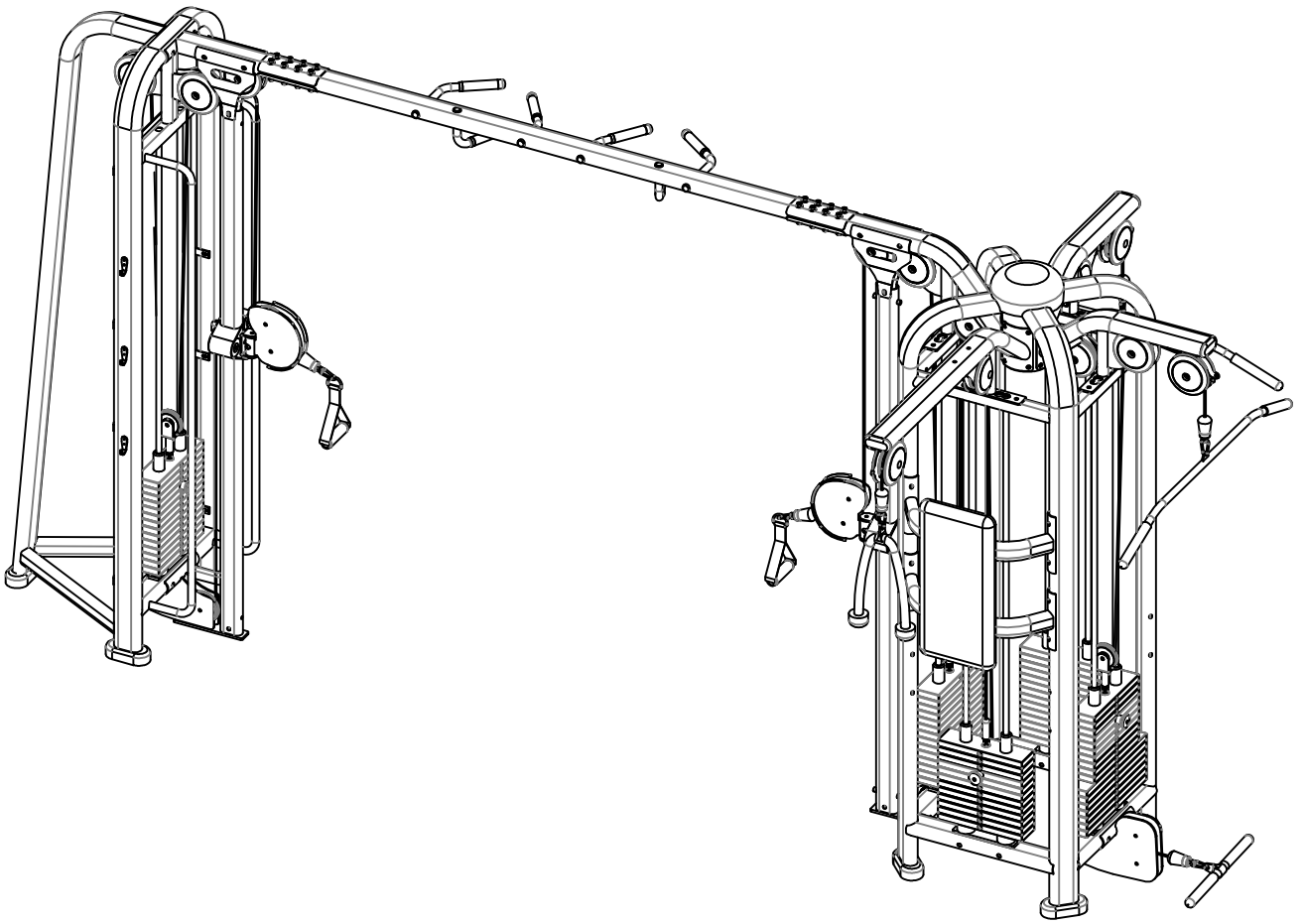

**COMPONENTI DI MONTAGGIO - 1**

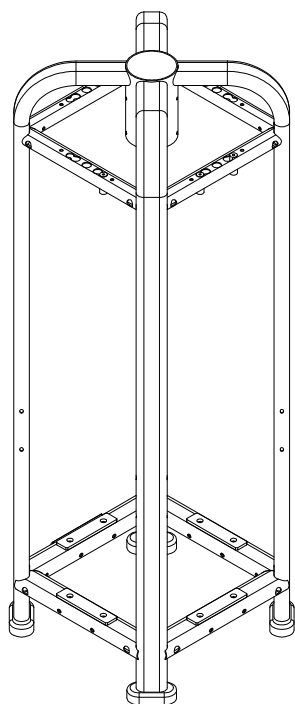

**1 (1pz)**



**2 (8pz)**



**3 (1pz)**



**4 (8pz)**



**5 (4pz)**



**6 (2pz)**



**7 (8pz)**



**8 (4pz)**

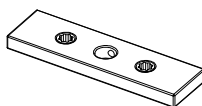

**9 (44pz)**



**10 (4pz)**

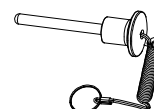

**11 (4pz)**



**12 (2pz)**

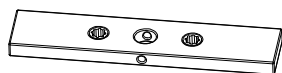

**13 (7pz)**

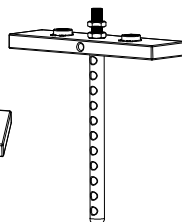

**14 (2pz)**

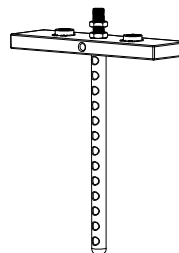

**15 (1pz)**

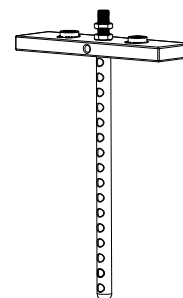

**16 (1pz)**

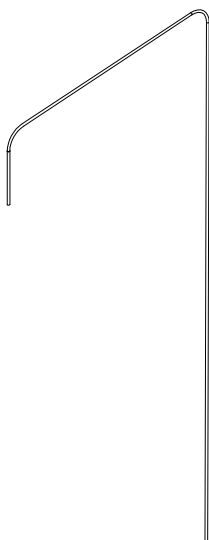

**17 (1pz)**

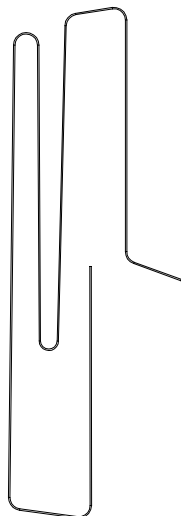

**18 (1pz)**

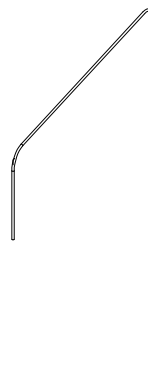

**19 (1pz)**

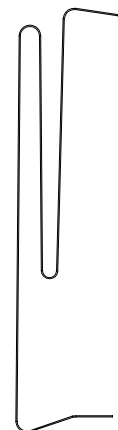

**20 (1pz)**



**COMPONENTI DI MONTAGGIO - 2**

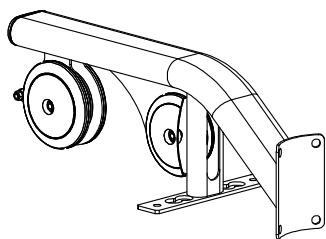

**22** (1pz)

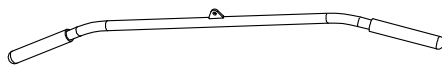

**23** (2pz)

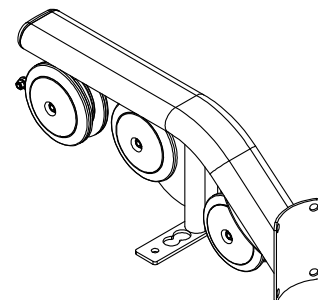

**24** (1pz)

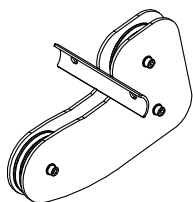

**25** (1pz)

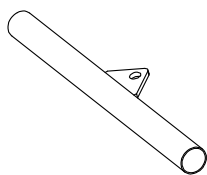

**26** (1pz)

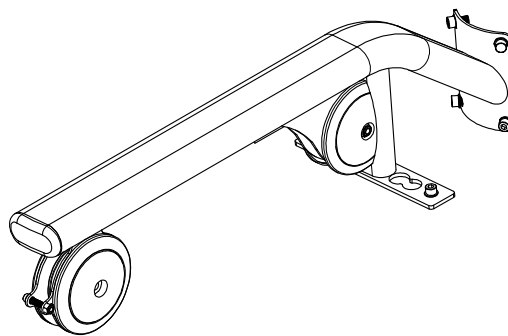

**27** (1pz)

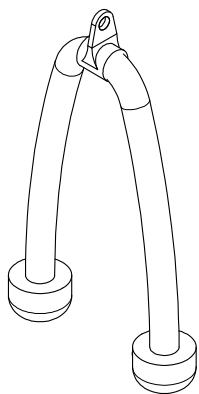

**28** (1pz)

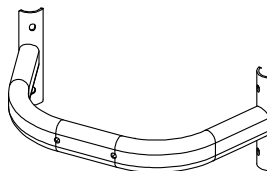

**29** (2pz)

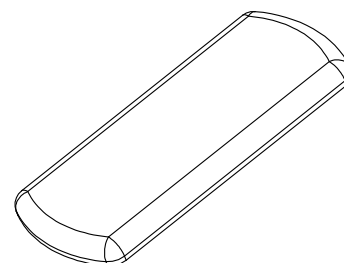

**30** (1pz)



## COMPONENTI DI MONTAGGIO - 3

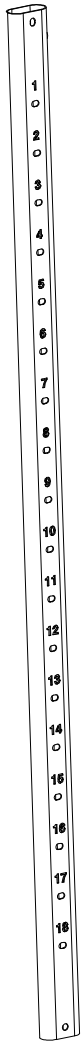

**31** (1pz)

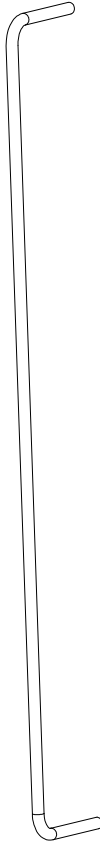

**69** (2pz)

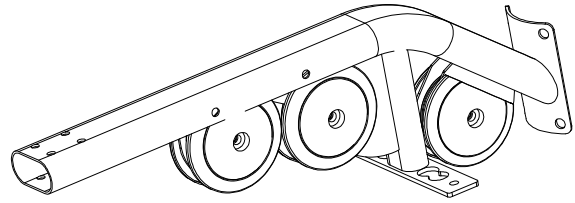

**32** (1pz)

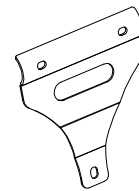

**33** (2pz)

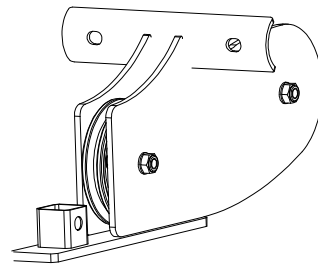

**34** (1pz)

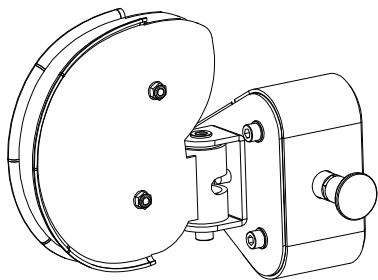

**35** (1pz)

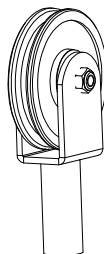

**36** (1pz)

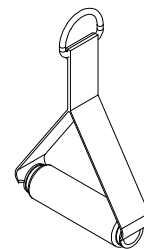

**37** (1pz)



**D) COMPONENTI DI MONTAGGIO STAZIONE 4**

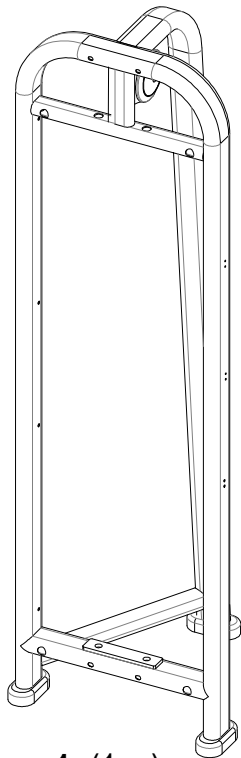

**1 (1pz)**



**2 (2pz)**

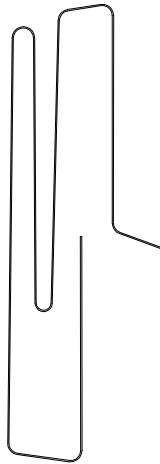

**3 (1pz)**



**4 (2pz)**



**5 (1pz)**

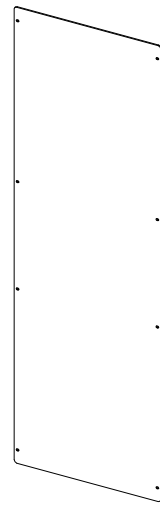

**6 (1pz)**

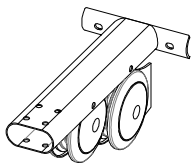

**7 (1pz)**



**8 (2pz)**

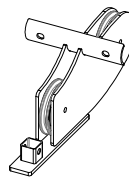

**9 (1pz)**

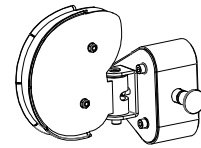

**10 (1pz)**

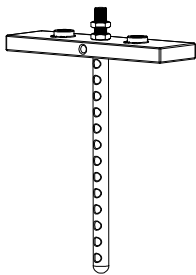

**11 (1pz)**

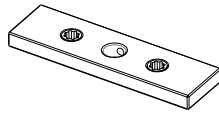

**12 (13pz)**



**13 (1pz)**



**14 (1pz)**



**15 (1pz)**



**16 (1pz)**



**37 (1pz)**



**17 (2pz)**



**18 (1pz)**



**19 (1pz)**













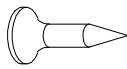
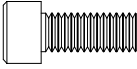

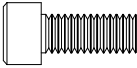

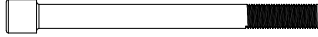
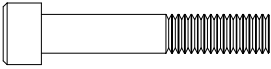
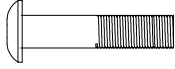
**20 (8pz)**

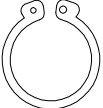

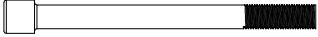
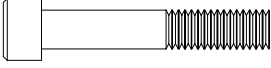
**21 (6pz)**



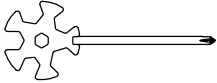

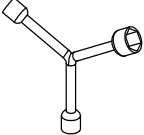





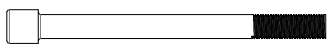
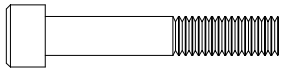
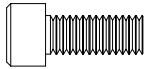

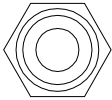

**FERRAMENTA DI MONTAGGIO (scala 1:1)**

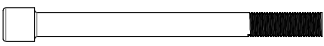
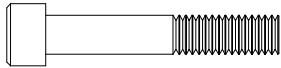
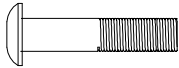
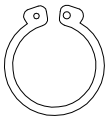
 <b>38</b> M5x35 mm (4pz)	 <b>39</b> M10x25 mm (16pz)	 <b>40</b> Ø10 mm (52pz)
 <b>41</b> M10x20 mm (8pz)	 <b>42</b> M10 (24pz)	 <b>43</b> M10x120 mm (12pz)
 <b>44</b> M10x65 mm (1pz)	 <b>45</b> M8x60 mm (12pz)	 <b>46</b> M8x25 mm (4pz)
 <b>47</b> Ø25 mm (8pz)	 <b>48</b> Ø8 mm (4pz)	 <b>49</b> M8x10 mm (18pz)
 <b>50</b> M10x130 mm (2pz)	 <b>51</b> M10x55 mm (1pz)	 <b>70</b> M10x30 mm (4pz)
		
		

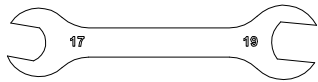

**F) FERRAMENTA DI MONTAGGIO STAZIONE 2**

 <p><b>22</b> Vite a brugola M10x120 (4 pz)</p>	 <p><b>23</b> Vite a brugola M10x70 (1 pz)</p>	 <p><b>24</b> Vite a brugola M10x30 (4 pz)</p>
 <p><b>25</b> Rondella piana Ø10 (20 pz)</p>	 <p><b>26</b> Dado autobloccante M10 (8 pz)</p>	 <p><b>27</b> Vite a brugola M6x20 (16 pz)</p>
 <p><b>28</b> Rondella piana Ø6 (40 pz)</p>	 <p><b>29</b> Dado autobloccante M6 (8 pz)</p>	 <p><b>30</b> Vite bombata M4x16 (12 pz)</p>
 <p><b>31</b> Vite a brugola M10x130 (2 pz)</p>	 <p><b>32</b> Vite a brugola M10x55 (1 pz)</p>	 <p><b>33</b> Vite a esagono inc. M8x60 (2 pz)</p>
 <p><b>34</b> Seeger Ø25 (2 pz)</p>	 <p><b>35</b> Grano M8x10 (8 pz)</p>	 <p><b>36</b> Vite a brugola M8x25 (2 pz)</p>
		
		



Il prodotto viene imballato smontato in più parti in maniera da occupare poco spazio; per poter utilizzare il prodotto occorre assemblarlo riferendosi alle operazioni di montaggio illustrate nelle pagine seguenti.

Prima di eseguire una operazione di montaggio occorre rispettare indicazioni specifiche riportate sul disegno, in particolare:



**La movimentazione e il montaggio dei componenti costituenti l'attrezzo devono essere eseguite da due persone, necessarie sia per assistere al posizionamento e al fissaggio dei componenti verticali che per aiutare nel sollevamento e movimentazione delle parti.**

**Alcune parti indicate nel manuale come da assemblare, possono trovarsi già pre-assemblate per agevolare il montaggio del prodotto.**

**Qualora si rilevino problemi o discordanze nelle fasi di montaggio del prodotto che possono comportare dei rischi strutturali per la sicurezza d'uso dell'attrezzo, è obbligatorio interrompere il montaggio e consultare immediatamente il servizio di assistenza per risolvere ogni dubbio.**

**Lista di attrezzi richiesti per il montaggio :**

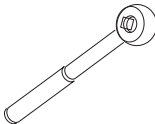
-  Chiave a cricchetto
-  Bussole per chiave a cricchetto
-  Chiave esagonale regolabile
-  Martello in gomma
-  Chiave a brugola
-  Giravite a croce

## FASE 1

Pos.	Descrizione	Q.tà
1	Telaio autoportante 4 stazioni	1
3	Cappello di copertura superiore	1

Pos.	Descrizione	Q.tà
6	Inserto superiore	1
50	Vite autofilettante M5x35 mm	4

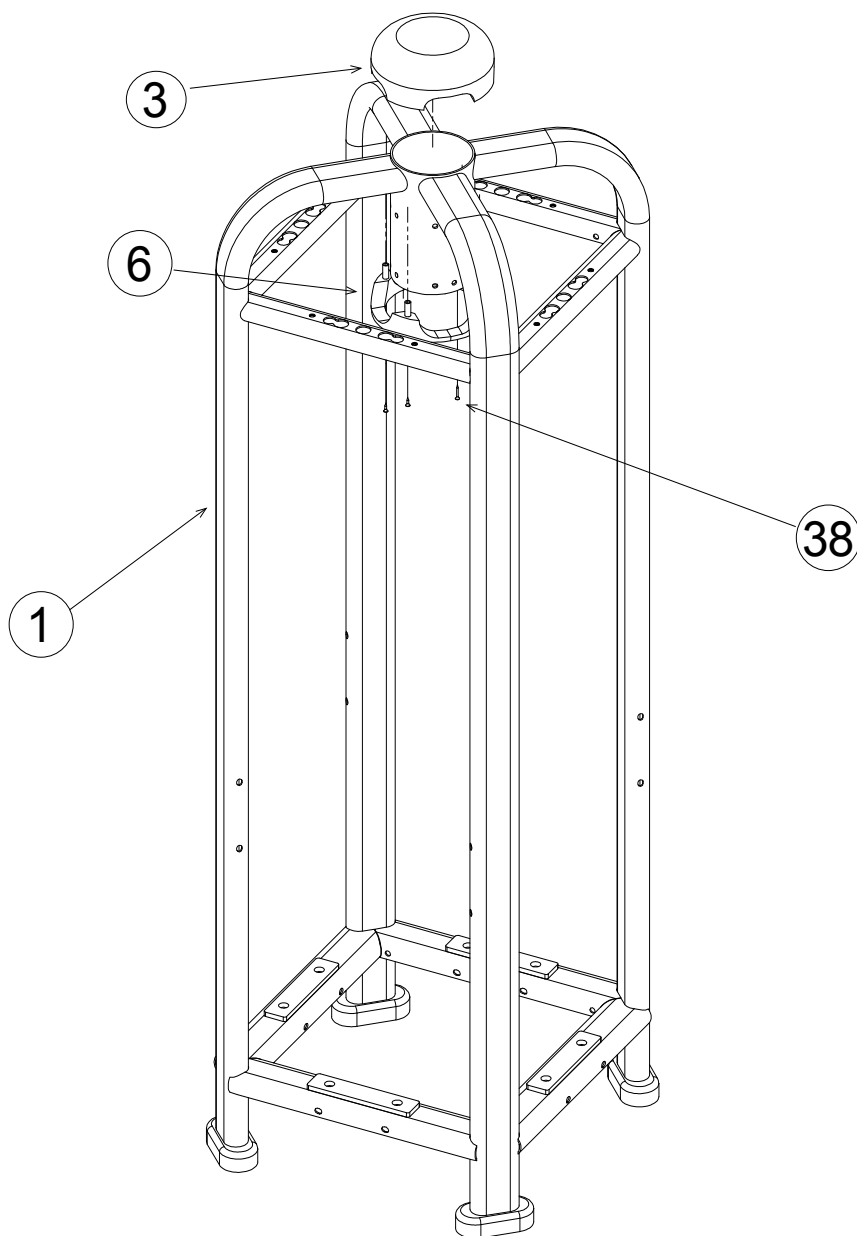

**MONTAGGIO STRUTTURA AUTOPORTANTE**

## FASE 2

Pos.	Descrizione	Q.tà
1	Telaio autoportante per 4 stazioni	1
2	Guida di scorrimento pacco pesi	2
4	Respingente in gomma base pacco pesi	2
5	Finecorsa conico per attacco cavo d'acciaio	1
7	Cilindro di allineamento e fissaggio guide	2
8	Attacco terminale per cavo d'acciaio	1
10	Moschettone	1
12	Cilindro di arresto per cavo d'acciaio	1
17	Cavo d'acciaio per Lat Pull down	1

Pos.	Descrizione	Q.tà
22	Trave superiore a sbalzo I	1
23	Accessorio: Barra Lat	1
39	Vite a brugola M10x25 mm	4
40	Rondella Ø10 mm	6
41	Vite a brugola M10x20 mm	2
42	Dado autobloccante M10	2
45	Vite a esagono incassato M8x60 mm	2
46	Vite a brugola M8x25 mm	2
47	Seeger Ø25 mm	2

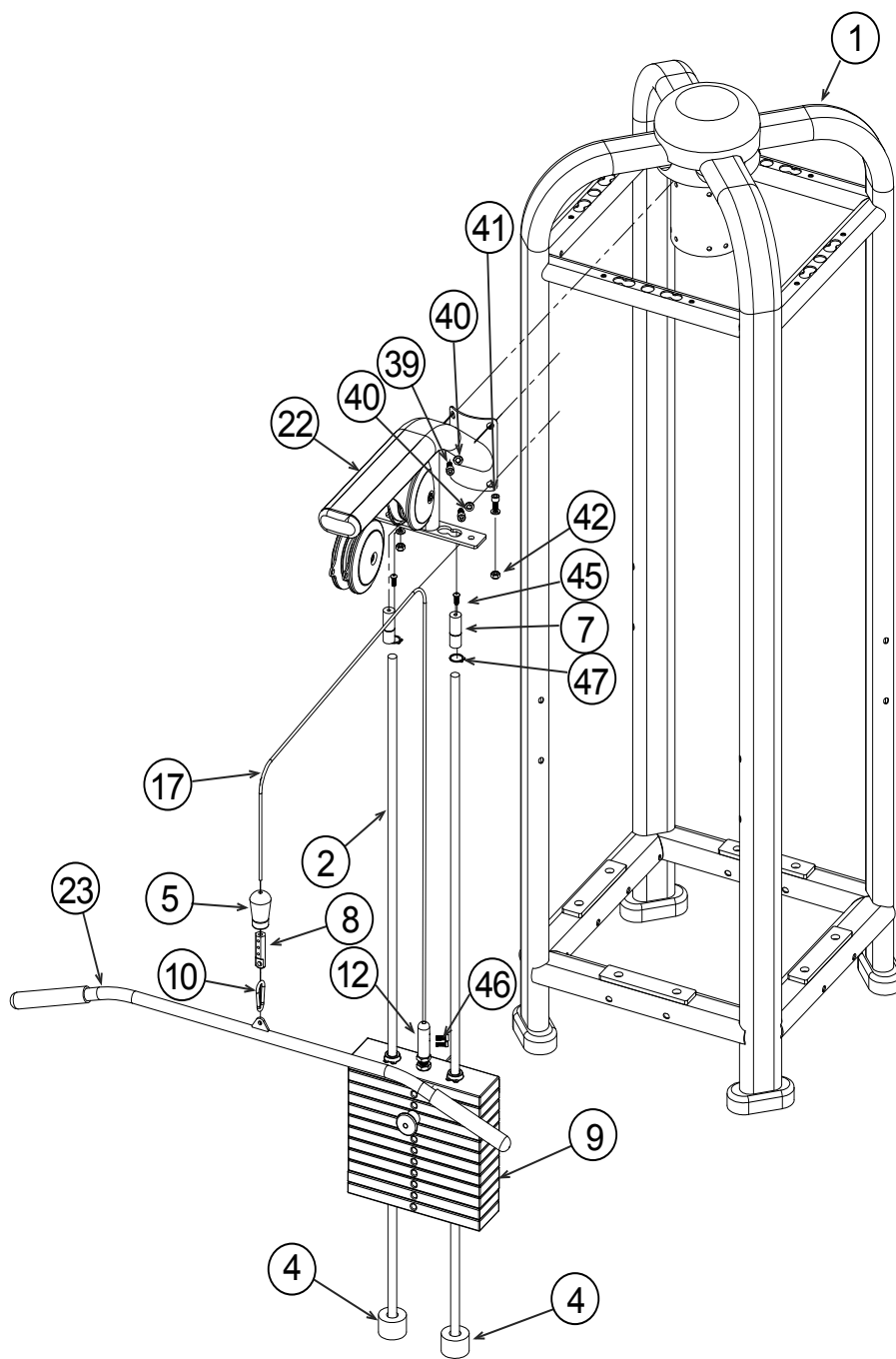

### MONTAGGIO STAZIONE LAT PULL DOWN



## FASE 3

Pos.	Descrizione	Q.tà
21	Tappo ovale 50x100x2 mm	1
22	Trave superiore a sbalzo I	1
42	Dado autobloccante M10	3
48	Rondella piana Ø8 mm	2
52	Vite a brugola M10x65 mm	2

Pos.	Descrizione	Q.tà
53	Boccola	4
54	Coperchio copri puleggia I	2
55	Coperchio copri puleggia 3	2
56	Vite a brugola M10x45 mm	1
57	Puleggia Ø110 mm	2

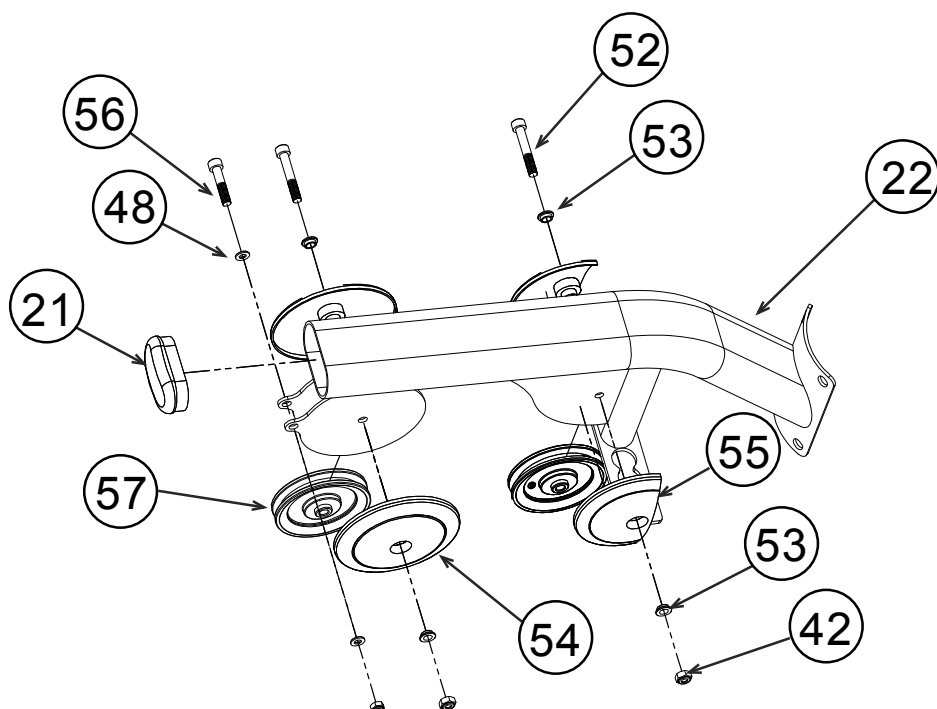

**ASSEMBLAGGIO TRAVE A SBALZO I (STAZIONE PULL DOWN I)**



## FASE 4

Pos.	Descrizione	Q.tà
9	Piastra peso da 5 kg	11
11	Perno di selezione pesi	1
14	Piastra base 5 kg con asta di selezione peso	1

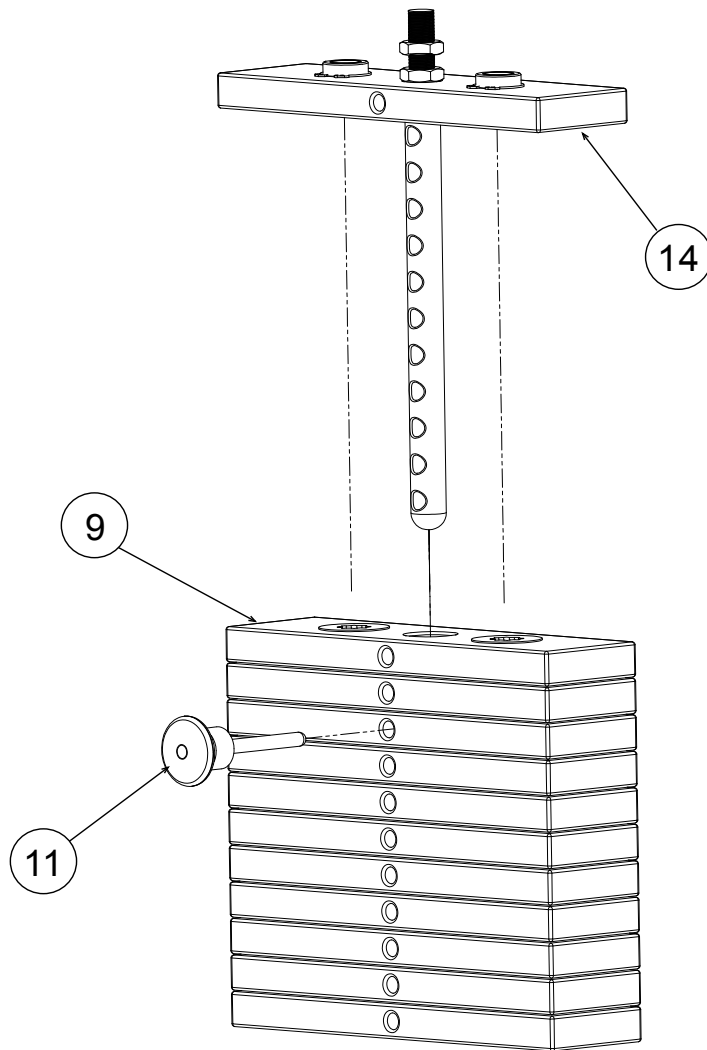

**ASSEMBLAGGIO PACCO PESI PER STAZIONE LAT PULL DOWN**



## FASE 5

Pos.	Descrizione	Q.tà
1	Telaio autoportante 4 stazioni	1
2	Guida di scorrimento pacco pesi	2
4	Respingente in gomma base pacco pesi	2
5	Finecorsa conico per attacco cavo d'acciaio	2
7	Cilindro di allineamento e fissaggio guide	2
8	Attacco terminale per cavo d'acciaio	2
10	Moschettone	2
20	Cavo d'acciaio stazioni superiore e inferiore	1
23	Accessorio: Barra Lat	1
24	Trave superiore a sbalzo 2	1

Pos.	Descrizione	Q.tà
25	Porta pulegge inferiore per pull up	1
26	Accessorio: Barra corta	1
39	Vite a brugola M10x25 mm	4
40	Rondella piana Ø10 mm	10
41	Vite a brugola M10x20 mm	2
42	Dado autobloccante M10	4
43	Vite a brugola M10x120 mm	2
45	Vite a esagono incassato M8x60 mm	2
47	Seeger Ø25 mm	2

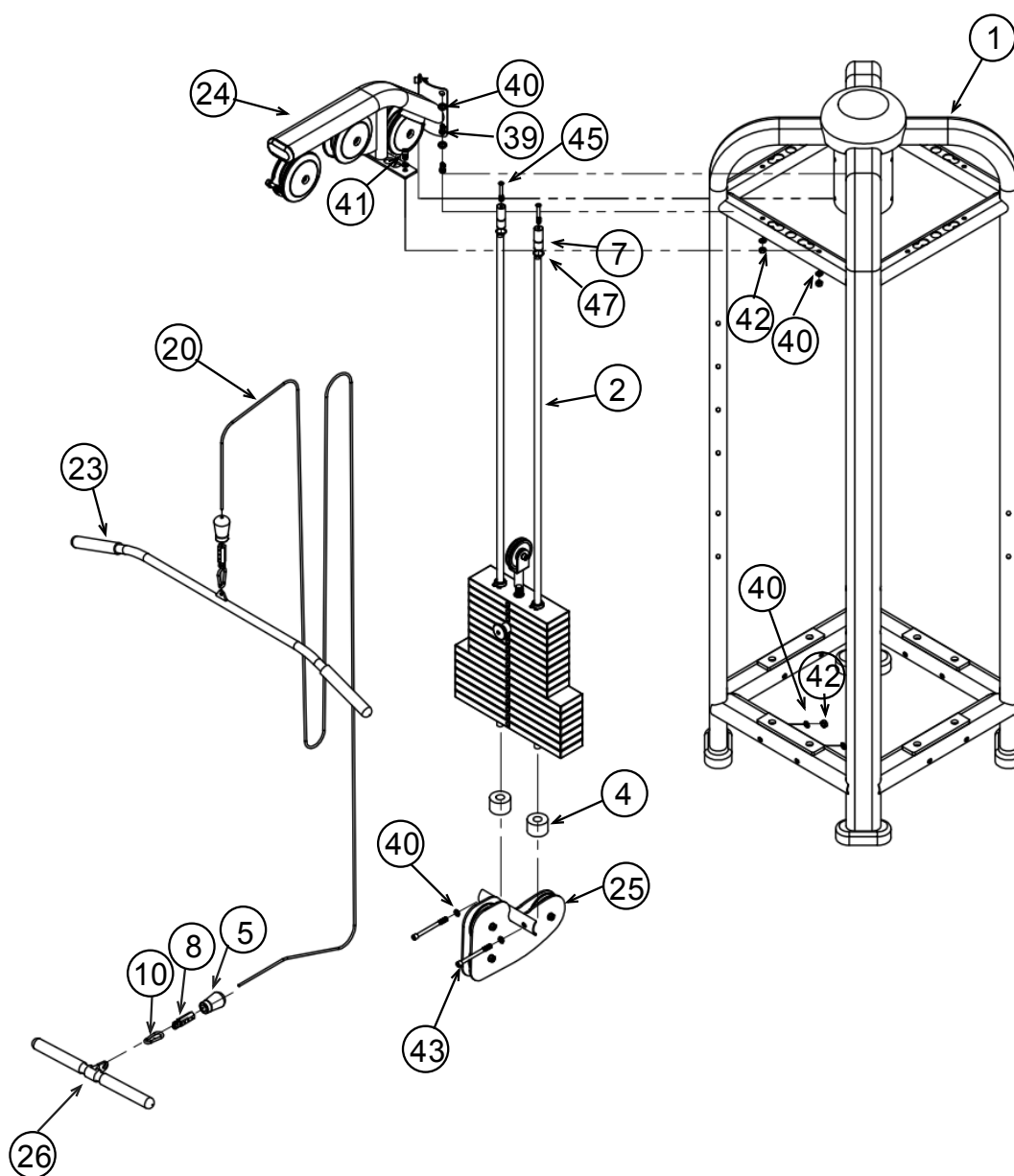

### MONTAGGIO STAZIONE PULL UP & PULL DOWN





## FASE 7

Pos.	Descrizione	Q.tà
25	Porta pulegge triplo	1
42	Dado autobloccante M10	3
48	Rondella piana Ø8 mm	6

Pos.	Descrizione	Q.tà
57	Puleggia Ø110 mm	3
59	Vite a brugola M10x50 mm	3

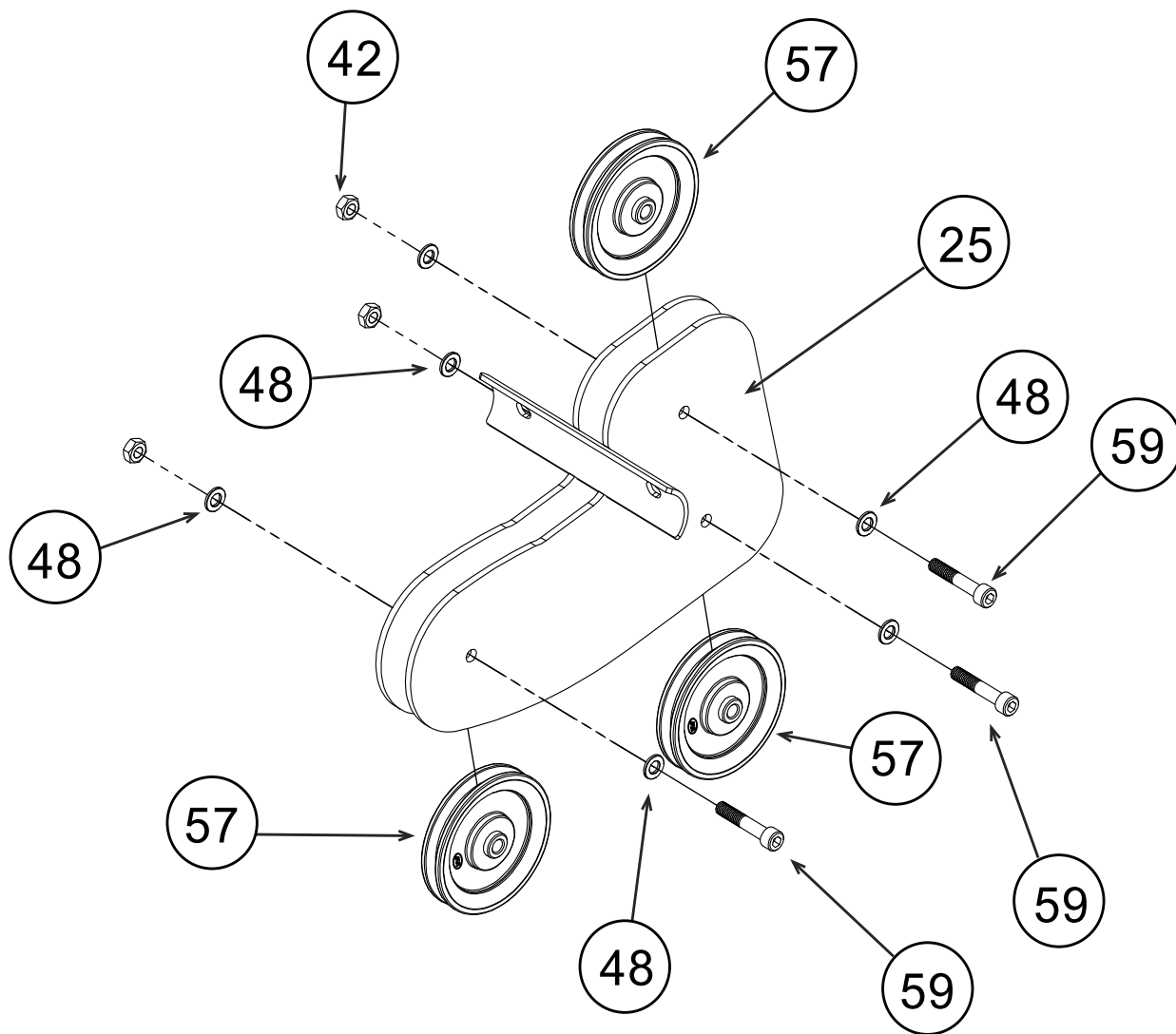

**MONTAGGIO PORTA PULEGGE INFERIORE STAZIONE PULL UP**





## FASE 8

Pos.	Descrizione	Q.tà
9	Piastra peso da 5 kg	9
11	Perno di selezione pesi	1
13	Piastra peso da 7,5 kg	7
16	Piastra base con asta di selezione peso	1

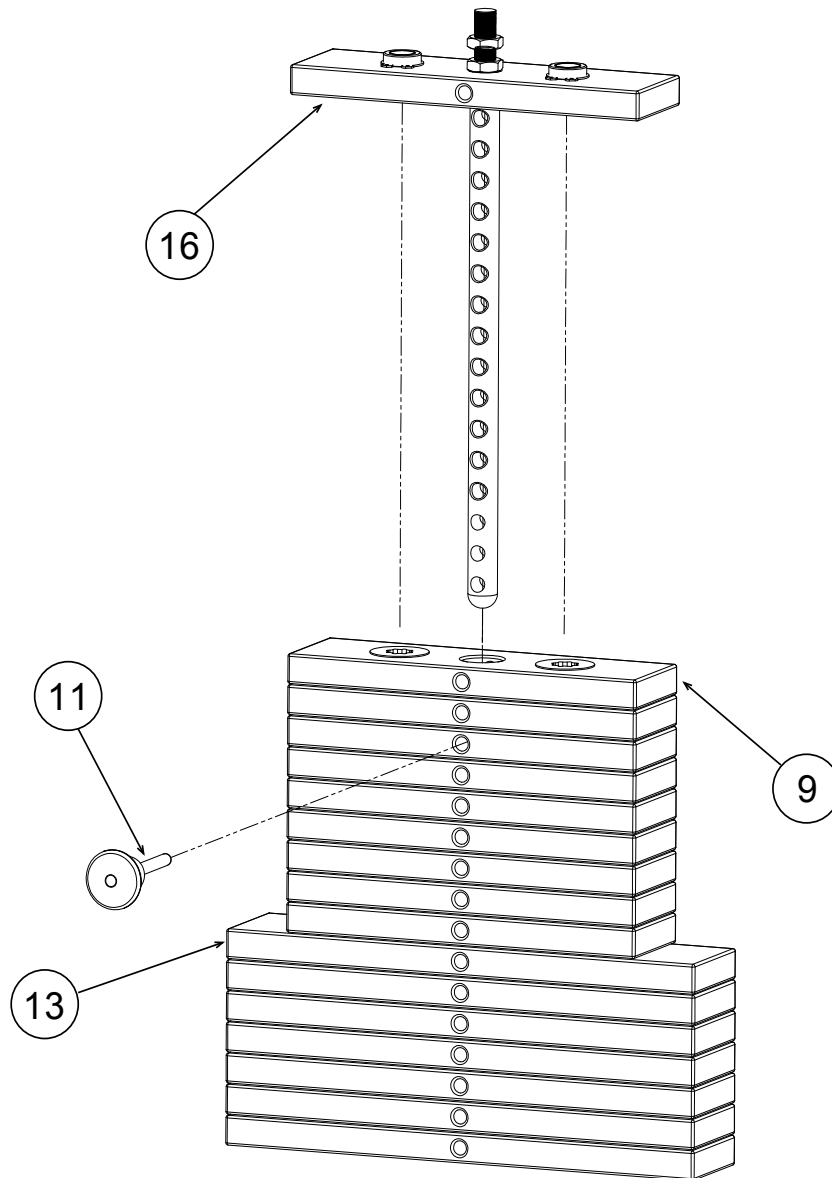

**ASSEMBLAGGIO PACCO PESI PER STAZIONE PULL UP & PULL DOWN**



## FASE 9

Pos.	Descrizione	Q.tà
1	Telaio autoportante 4 stazioni	1
2	Guida di scorrimento pacco pesi	2
4	Respingente in gomma base pacco pesi	2
5	Finecorsa conico per attacco cavo d'acciaio	1
7	Cilindro di allineamento e fissaggio guide	2
8	Attacco terminale per cavo d'acciaio	1
10	Moschettone	1
12	Cilindro di arresto per cavo d'acciaio	1
17	Cavo d'acciaio per Lat Pulldown	1
27	Tubolare superiore a sbalzo per pull down	1
28	Accessorio: Corda doppia	1

Pos.	Descrizione	Q.tà
29	Barra di fissaggio schienale	2
30	Schienale	1
39	Vite a brugola M10x25 mm	4
40	Rondella piana Ø10 mm	14
41	Vite a brugola M10x20 mm	2
42	Dado autobloccante M10	10
43	Vite a brugola M10x120 mm	8
45	Vite a esagono incassato M8x60 mm	6
46	Vite a brugola M8x25 mm	2
47	Seeger Ø25 mm	2
48	Rondella piana Ø8 mm	8

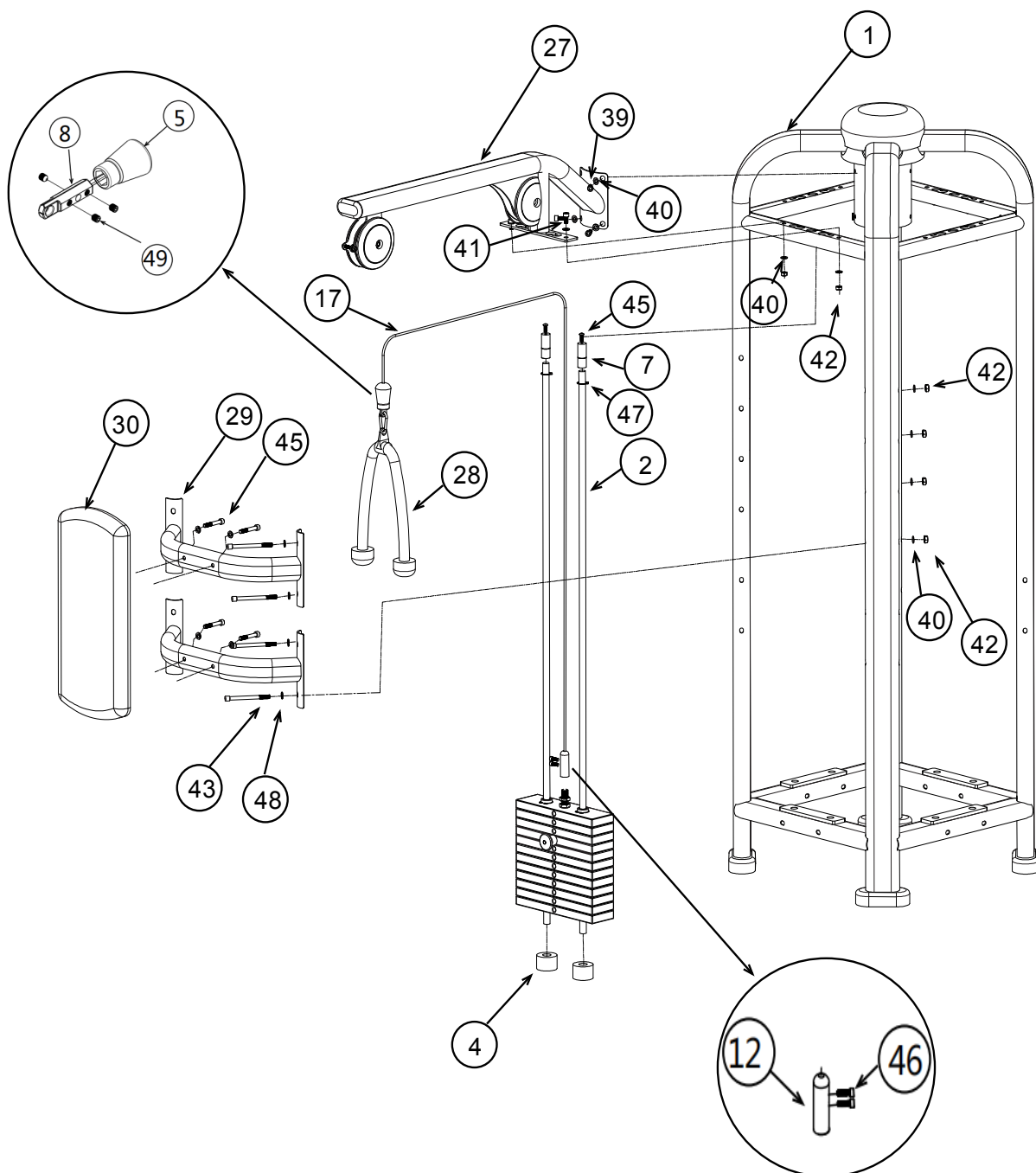

### MONTAGGIO STAZIONE TRICEPS



## FASE 10

Pos.	Descrizione	Q.tà
21	Tappo ovale 50x100x2 mm	1
27	Trave superiore a sbalzo 3	1
42	Dado autobloccante M10	3
48	Rondella piana Ø8 mm	2
52	Vite a brugola M10x65 mm	2

Pos.	Descrizione	Q.tà
53	Boccola	4
54	Coperchio copri puleggia I	2
55	Coperchio copri puleggia 3	2
56	Vite a brugola M10x45 mm	1
57	Puleggia Ø110 mm	2

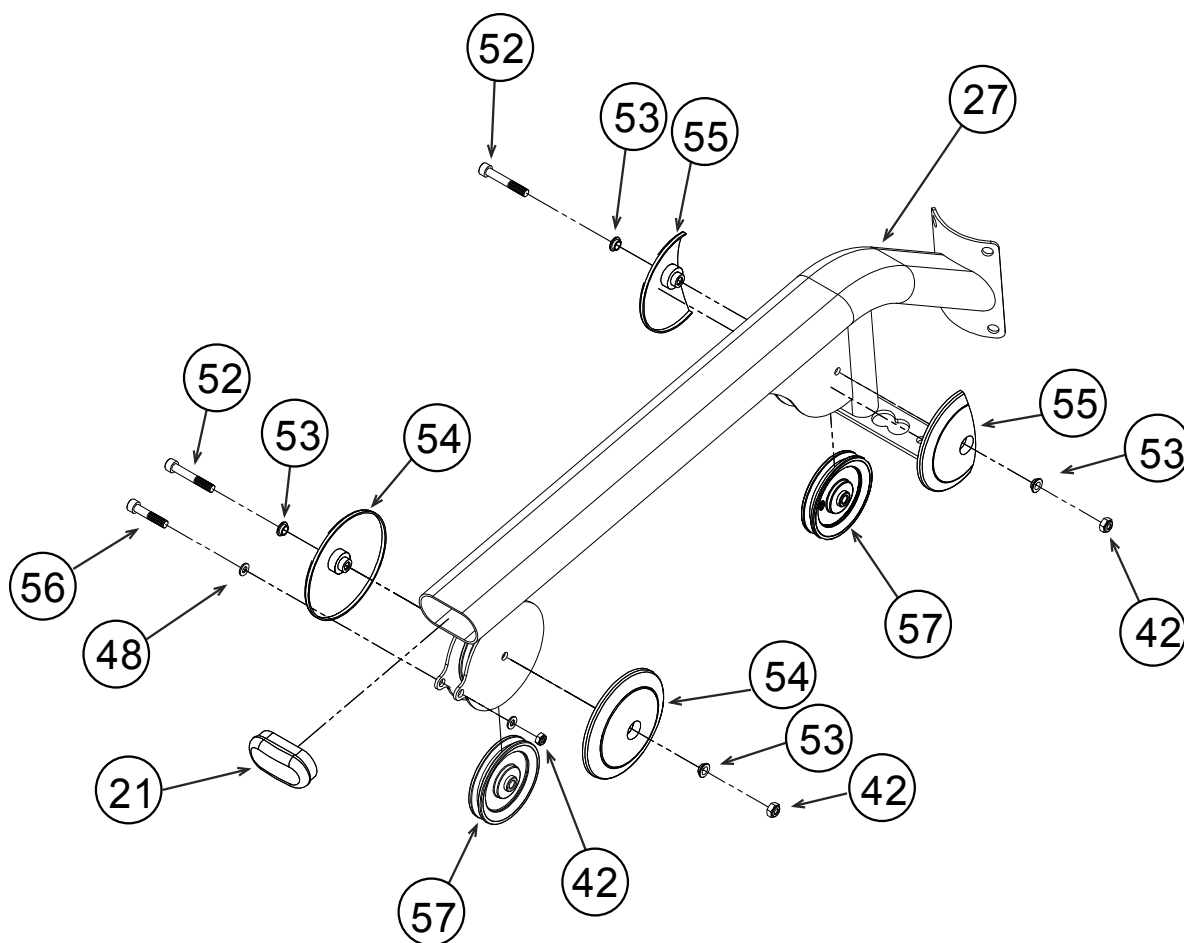

**ASSEMBLAGGIO TRAVE A SBALZO 3 (STAZIONE TRICEPS)**



**FASE 11**

Pos.	Descrizione	Q.tà
9	Piastra peso da 5 kg	11
11	Perno di selezione pesi	1
14	Piastra base 5 kg con asta di selezione peso	1

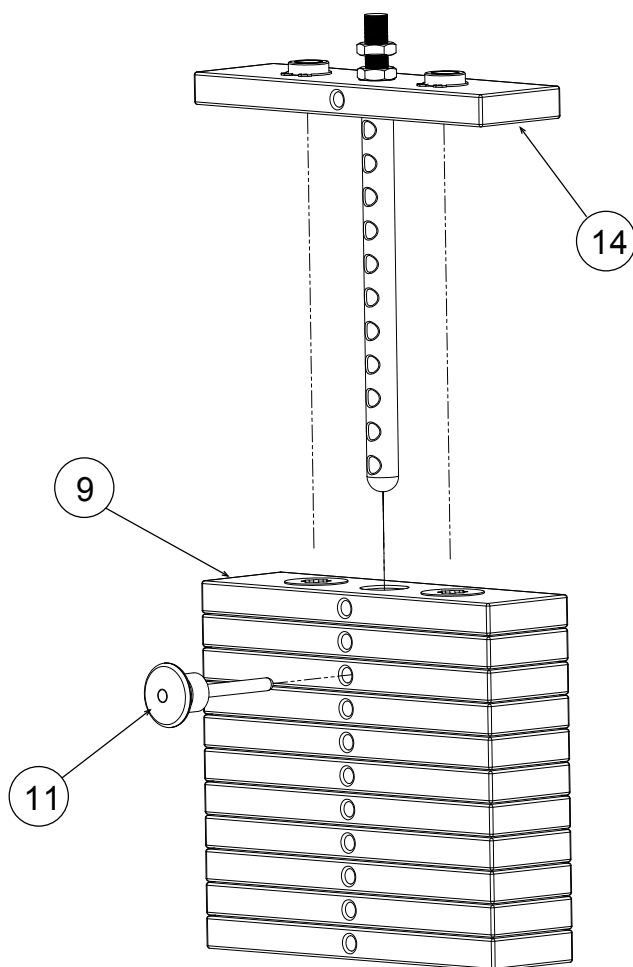
**ASSEMBLAGGIO PACCO PESI PER STAZIONE TRICEPS**

## FASE 12

Pos.	Descrizione	Q.tà
1	Telaio autoportante 4 stazioni	1
2	Guida di scorrimento pacco pesi	2
4	Respingente in gomma base pacco pesi	2
5	Finecorsa conico per attacco cavo d'acciaio	1
7	Cilindro di allineamento e fissaggio guide	2
8	Attacco terminale per cavo d'acciaio	1
10	Moschettone	2
18	Cavo d'acciaio stazione poliercolina	1
31	Guida di scorrimento carrello	1
32	Trave superiore a sbalzo 4	1
33	Staffa di sostegno guida carrello	2
34	Porta pulegge doppio inferiore	1
35	Carrello cross bar	1
36	Porta puleggia singolo	1
37	Maniglia per trazioni	1

Pos.	Descrizione	Q.tà
39	Vite a brugola M10x25 mm	4
40	Rondella piana Ø10 mm	14
41	Vite a brugola M10x20 mm	2
42	Dado autobloccante M10	9
43	Vite a brugola M10x120 mm	2
45	Vite a esagono incassato M8x60 mm	2
47	Seeger Ø25 mm	2
48	Rondella piana Ø8 mm	2
49	Grano M8x10 mm	2
50	Vite a brugola M10x130 mm	2
56	Vite a brugola M10x45 mm	1
57	Puleggia Ø110 mm	1
69	Maniglione di presa	2
70	Vite a brugola M10x30 mm	4

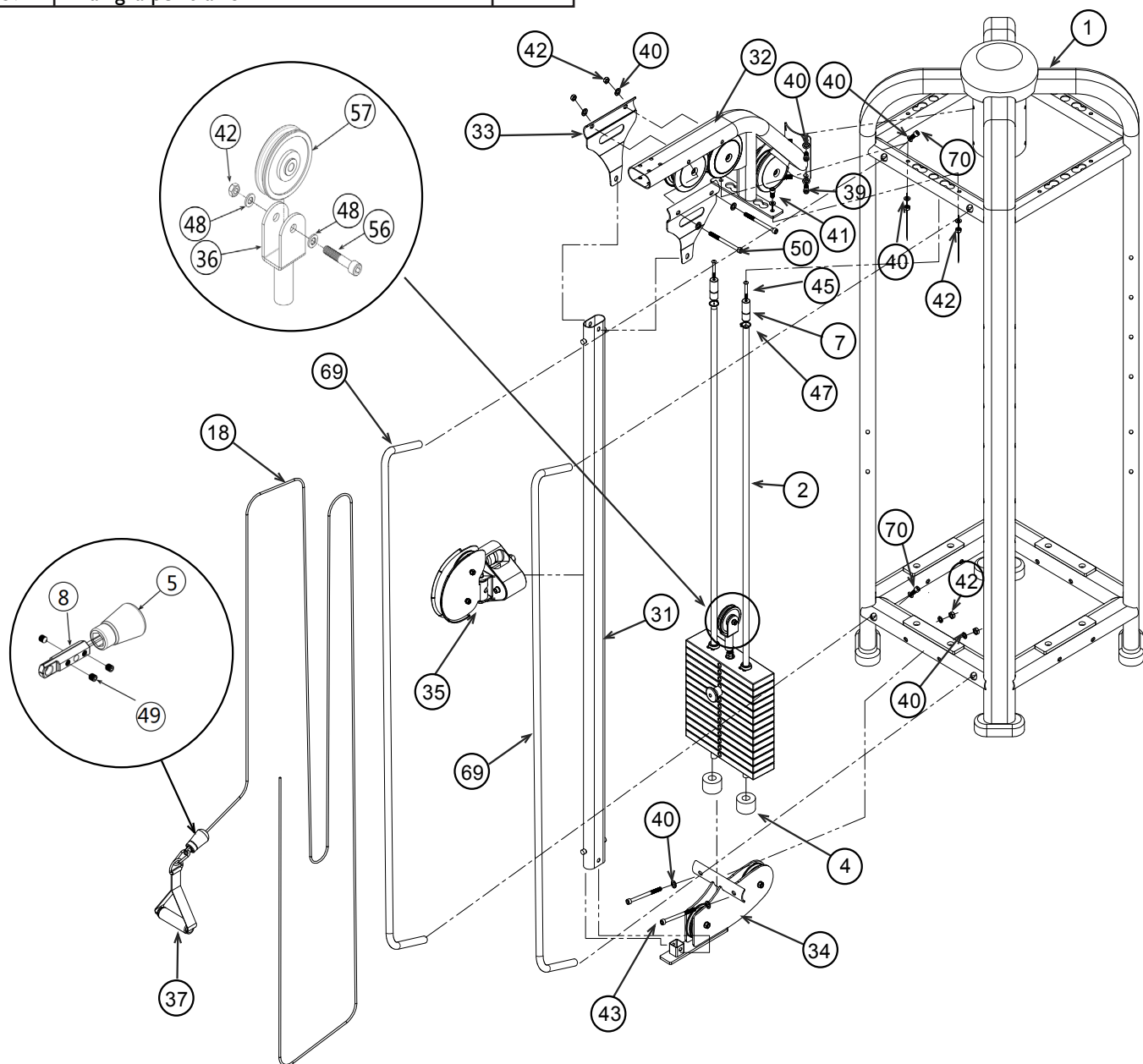

### MONTAGGIO STAZIONE POLIERCOLINA SINGLE CROSS CABLE

## FASE 13

Pos.	Descrizione	Q.tà
31	Guida di scorrimento carrello	1
33	Staffe di sostegno guida carrello	2
40	Rondella piana Ø10 mm	4
42	Dado autobloccante M10	2
44	Vite a brugola M10x70 mm	1

Pos.	Descrizione	Q.tà
51	Vite M10x55 mm	1
60	Vite a brugola M8x100 mm	2
61	Dado autobloccante M8	2
62	Respingente di fine corsa on gomma	4

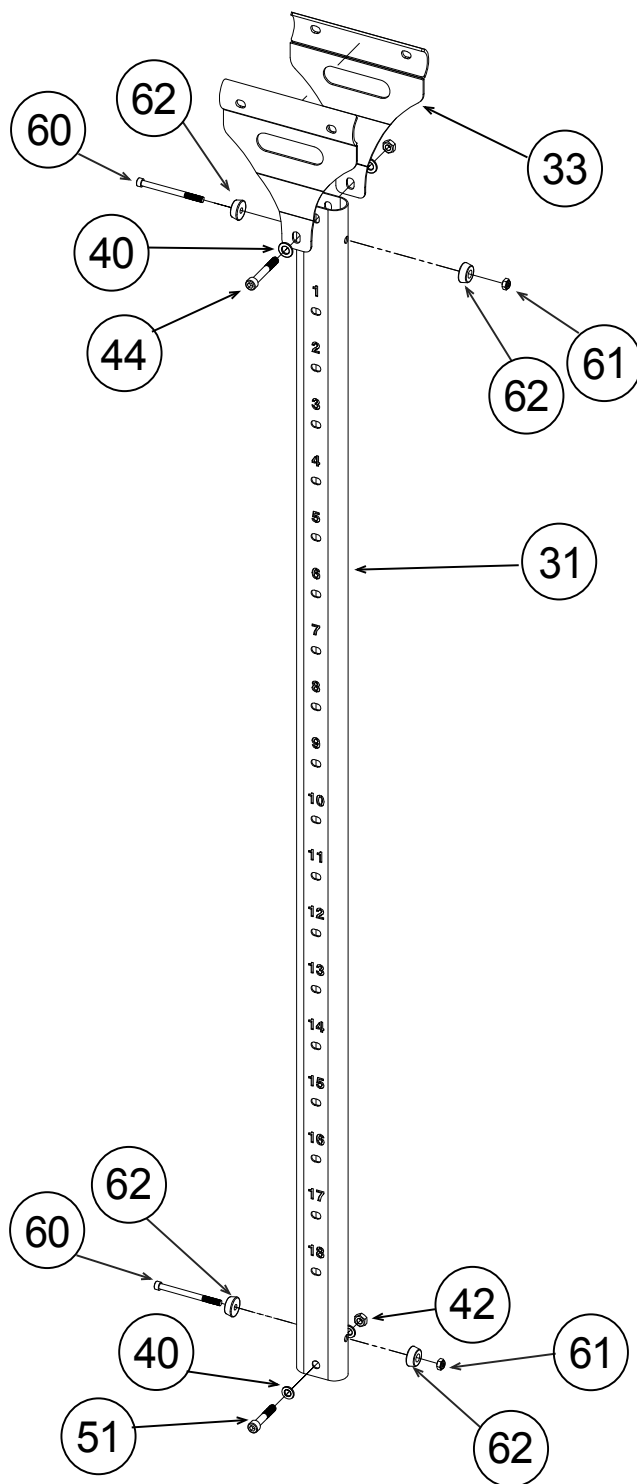

### MONTAGGIO GUIDA DI SCORRIMENTO CARRELLO



## FASE 14

Pos.	Descrizione	Q.tà
32	Trave superiore a sbalzo 4	1
42	Dado autobloccante M10	3
52	Vite a brugola M10x65 mm	3
53	Boccola	6

Pos.	Descrizione	Q.tà
54	Coperchio copri puleggia 1	4
57	Puleggia Ø110 mm	3
58	Coperchio copri puleggia 2	2

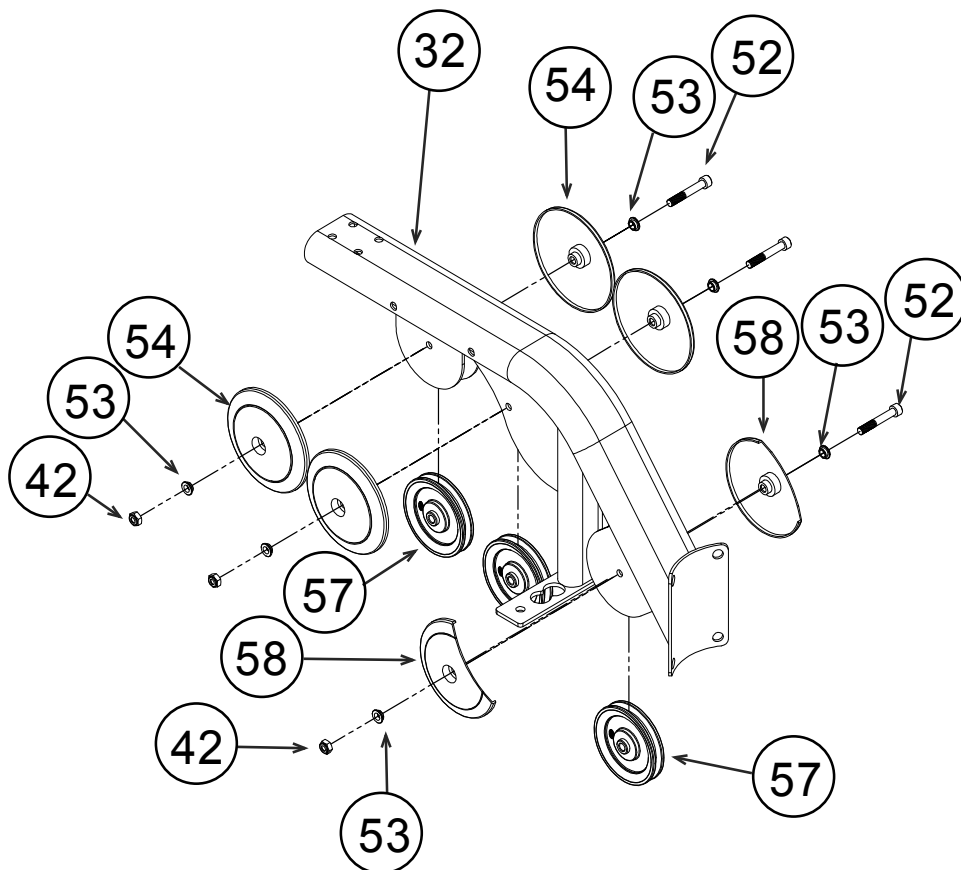

**ASSEMBLAGGIO TRAVE A SBALZO 4 (STAZIONE POLIERCOLINA)**



## FASE 15

Pos.	Descrizione	Q.tà
34	Porta pulegge doppio	1
42	Dado autobloccante M10	2
48	Rondella piana Ø8 mm	4

Pos.	Descrizione	Q.tà
57	Puleggia Ø110 mm	2
59	Vite a brugola M10x50 mm	2

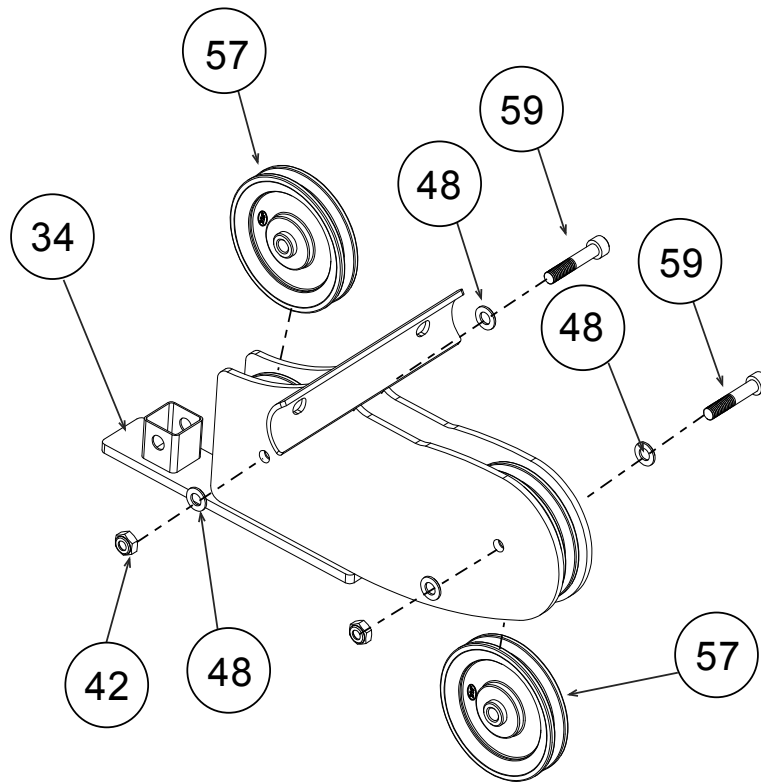

**MONTAGGIO PORTA PULEGGE DOPPIO INFERIORE**





## FASE 16

Pos.	Descrizione	Q.tà
9	Piastra peso da 5 kg	13
11	Perno di selezione pesi	1
15	Piastra base 5 kg con asta di selezione peso	1

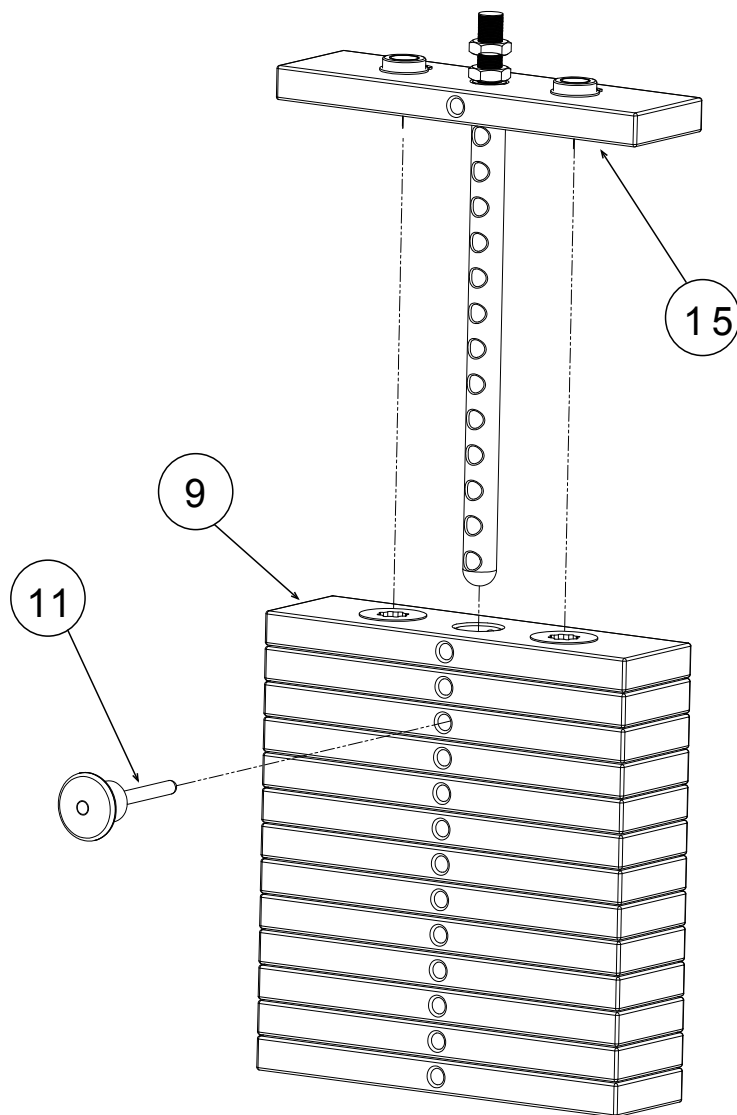

**ASSEMBLAGGIO PACCO PESI STAZIONE POLIERCOLINA**



## FASE 13

Pos.	Descrizione	Q.tà
1	Telaio colonna pacco pesi stazione	1
2	Guida di scorrimento pacco pesi	2
4	Corrimano stazione pulley	2
5	Guida di scorrimento carrello	1
6	Pannello posteriore protezione pacco pesi	1
7	Tubolare superiore a sbalzo	1
8	Staffe di sostegno guida carrello	2
9	Porta pulegge inferiore	1
10	Carrello scorrevole	1
13	Porta puleggia singolo con puleggia	1
14	Molla smorzatrice per sostegno pacco pesi	2

Pos.	Descrizione	Q.tà
20	Staffa di fissaggio pannello di protezione	8
21	Gancio porta accessori	6
22	Vite a brugola M10x120 mm	4
23	Vite a brugola M10x70 mm	1
24	Vite a brugola M10x30 mm	4
26	Dado autobloccante M10	8
27	Vite a brugola M6x20 mm	16
28	Rondella piana Ø6 mm	40
29	Dado autobloccante M6	8
30	Vite bombata M4x16 mm	12
31	Vite a brugola M10x130 mm	2

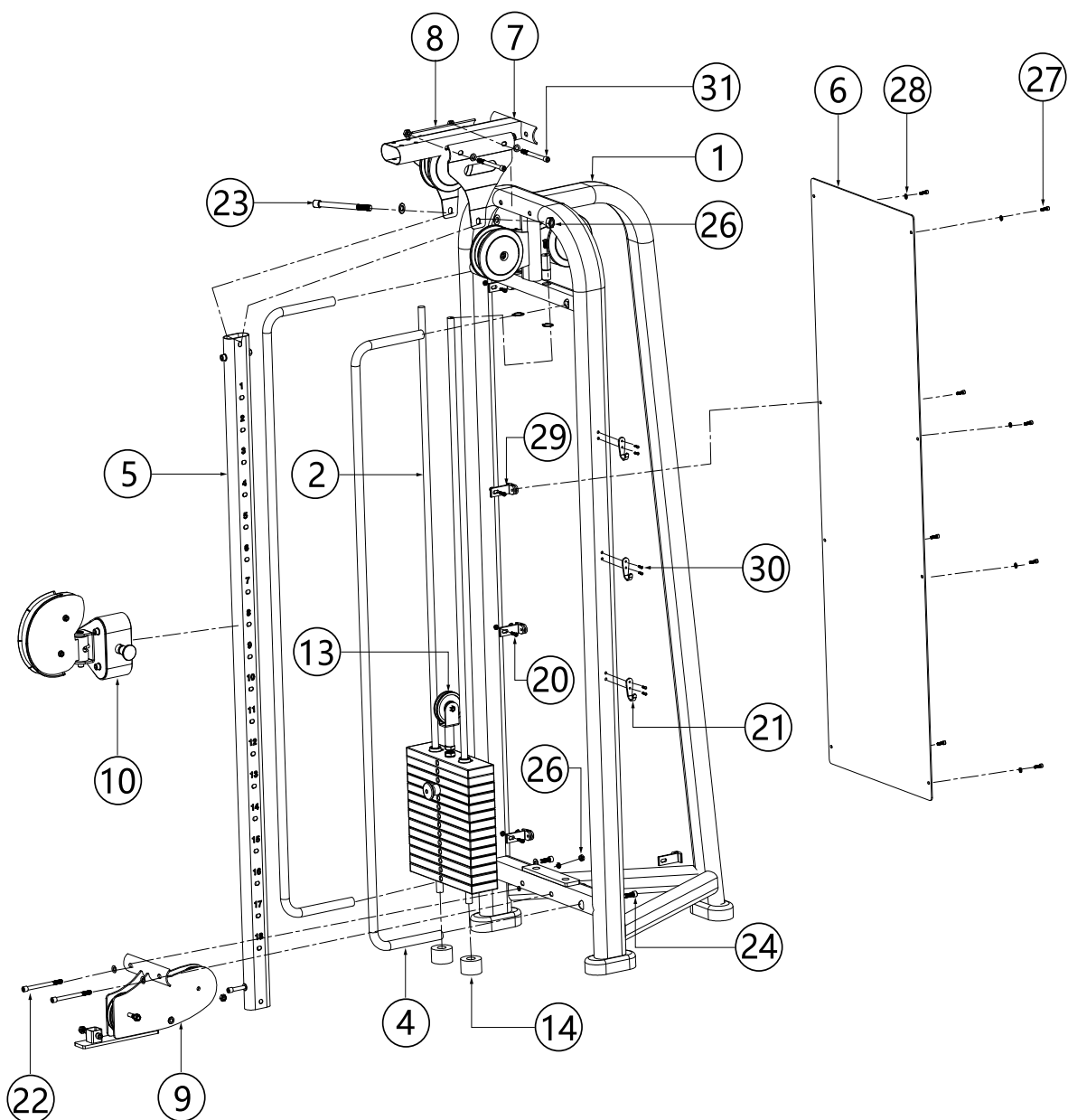

**NOTA:** con uguali procedure assemblare la colonna pacco pesi stazione 2.

### MONTAGGIO STRUTTURA PORTANTE STAZIONE I



## FASE 14

Pos.	Descrizione	Q.tà
5	Guida di scorrimento carrello	1
8	Staffe di sostegno guida carrello	2
23	Vite a brugola M10x70 mm	1

Pos.	Descrizione	Q.tà
25	Rondella piana Ø10 mm	4
26	Dado autobloccante M10	2
32	Vite M10x55 mm	1

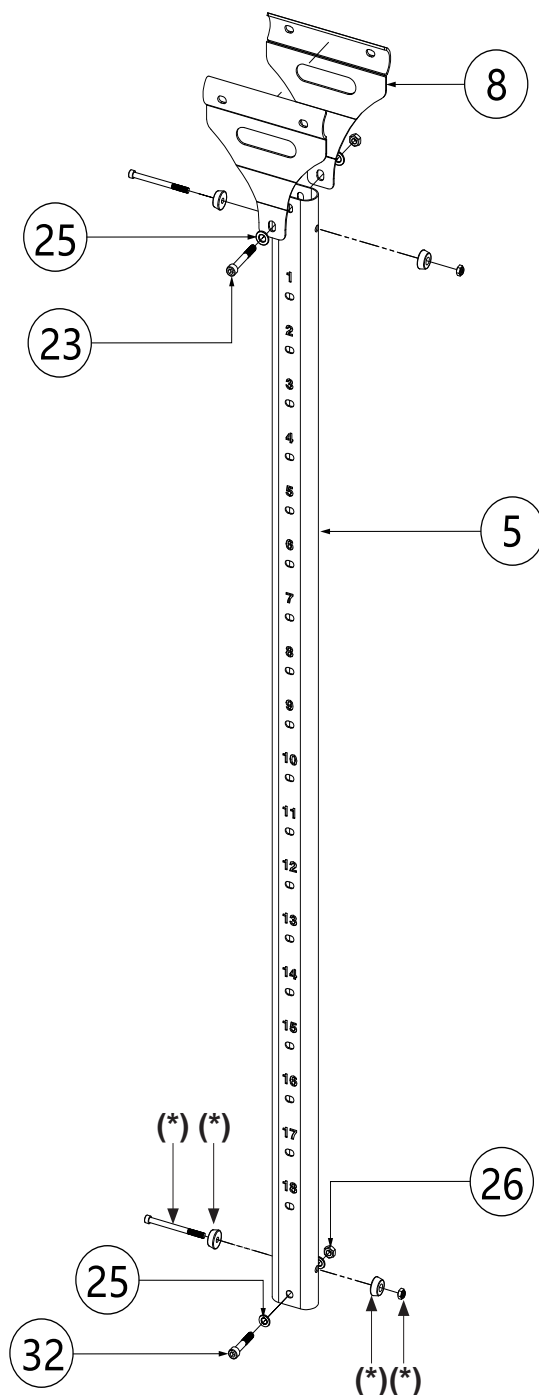

(\*) i finecorsa del carrello si trovano già pre-assemblati sulla guida.

### MONTAGGIO GUIDA DI SCORRIMENTO CARRELLO STAZIONE 2





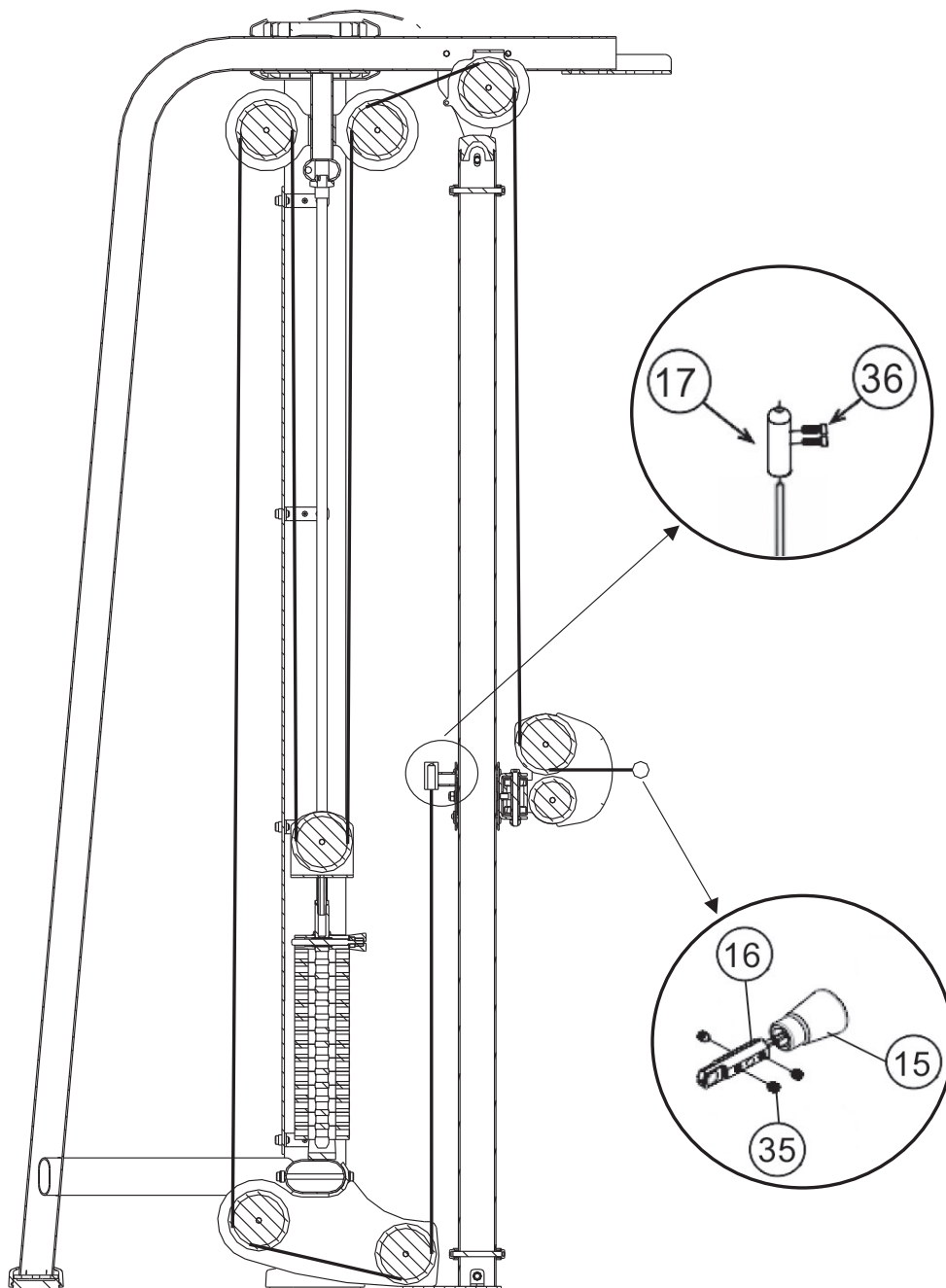

## FASE 16

Pos.	Descrizione	Q.tà
15	Finecorsa conico per attacco cavo d'acciaio	1
16	Attacco terminale per cavo d'acciaio	1
17	Cilindro di arresto per cavo d'acciaio	1
35	Grano M8x10 mm	3
36	Vite M8x25 mm	2



### ASSEMBLAGGIO CAVO D'ACCIAIO STAZIONE 2

<p>3</p>  <p>M10X70MM Hex Bolt *16</p>	<p>4</p>  <p>10mm Washer*32</p>	<p>5</p>  <p>M10 Aircraft Nut *16</p>
---	--	--

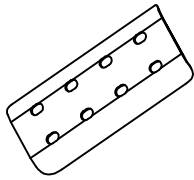

#2\*4

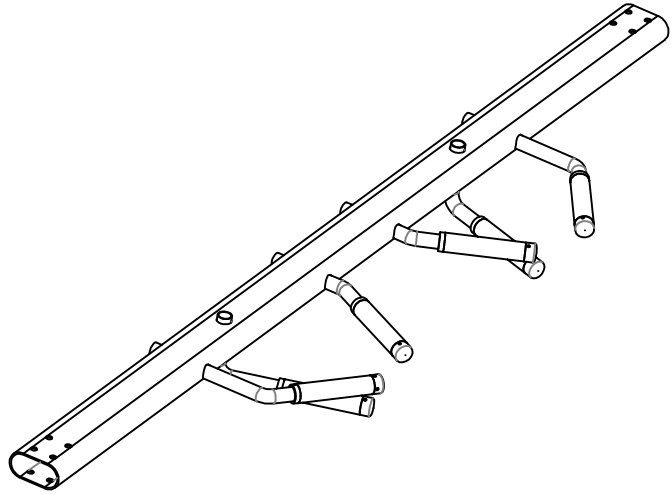

#1\*1

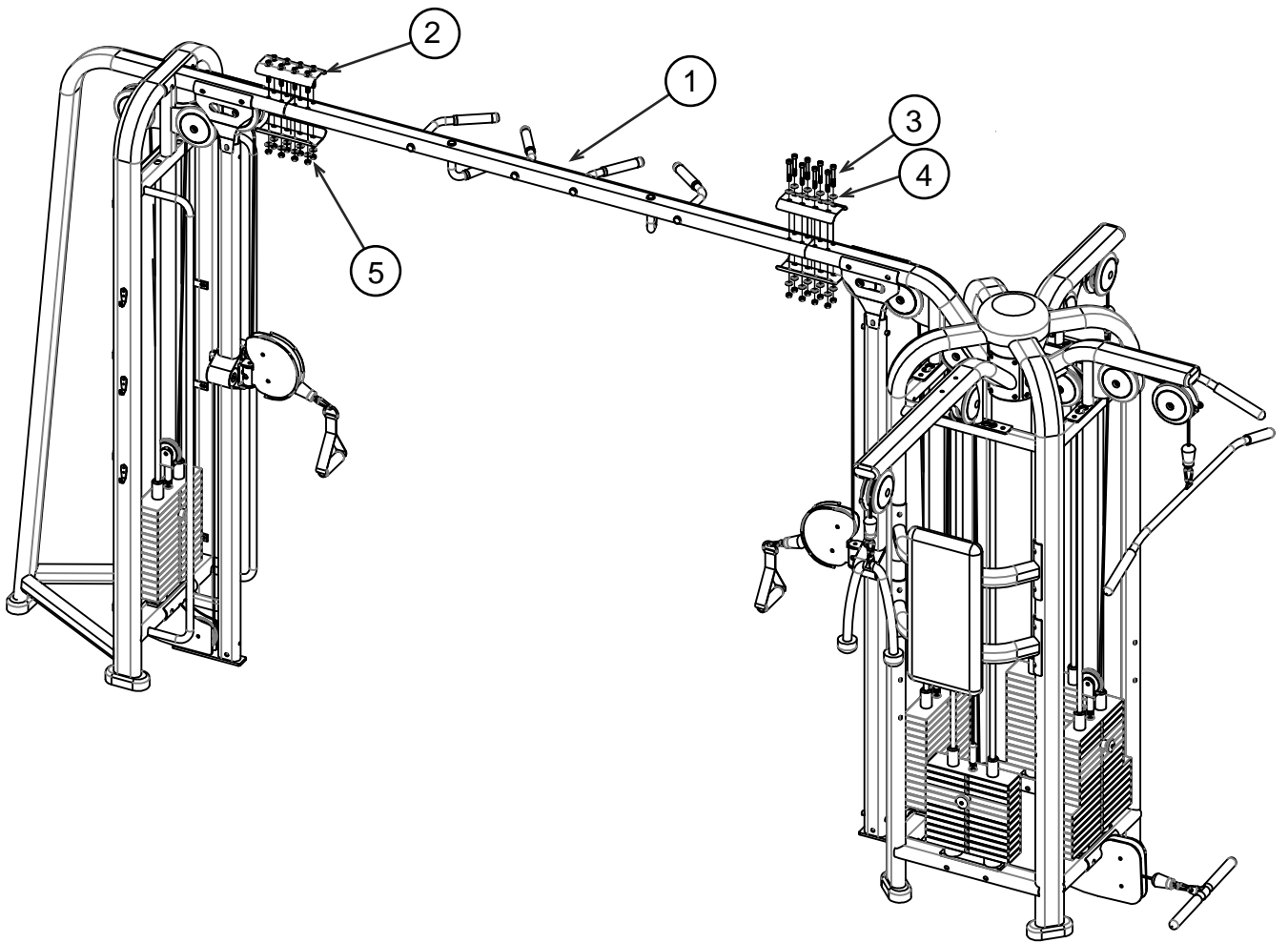



GARLANDO SPA  
Via Regione Piemonte, 32 - Zona Industriale D1  
15068 - Pozzolo Formigaro (AL) - Italy  
[contact@toorxprofessional.it](mailto:contact@toorxprofessional.it)  
[www.toorxprofessional.it](http://www.toorxprofessional.it)