

**TOORX**  
PROFESSIONAL LINE

# INSTRUCTION



**BRX**  
**AIRCROSS**  
**PRO**



Codice : GRLDTOORXBRXAIRC RP

Rev: 00

Ed: 03/25



## TABLE OF CONTENTS

Safety Instruction .....	2	Computer Instruction .....	11
Before You Begin .....	3	Operational Instruction .....	19
Equipment Warning, Caution & Notice Labels .....	4	Conditioning Guidelines .....	20
Hardware Identification Chart .....	5	Warm Up & Cool Down .....	21
Assembly Instruction .....	6	Product Parts Drawing .....	22
Setup Instruction .....	10	Parts List .....	23

## SAFETY INSTRUCTIONS

**⚠ WARNING** Consult your physician before starting this or any exercise program. This is especially important if you are over the age of 35, have never exercised before, are pregnant, or suffer from any health problem.  
Failure to follow all warnings and instructions could result in serious injury or death.

**⚠ WARNING** To reduce the risk of serious injury, read the following Safety Instructions before using the **Air Bike**.

1. Save these instructions and ensure that other exercisers read this manual prior to using the **Air Bike** for the first time.
2. Read all warnings and cautions posted on the
3. The **Air Bike** should only be used after a thorough review of the Owner's Manual. Make sure that it is properly assembled and tightened before use.
4. We recommend that two people be available for assembly of this product.
5. Keep children away from the **Air Bike**. Do not allow children to use or play on the **Air Bike**. Keep children and pets away from the **Air Bike** at all times.
6. The **Air Bike** is not a freewheeling exercise bike; therefore, pedal speed should be reduced in a controlled manner to prevent injury from spinning pedals.
7. It is recommended that you place this product on an equipment mat.
8. Set up and operate the **Air Bike** on a solid level surface. Do not position the **Air Bike** on loose rugs or uneven surfaces.
9. Make sure that adequate space is available for access to and around the **Air Bike**.
10. Adjust the **STANDS** on the rear stabilizer so that the bike sits on the floor without rocking.
11. Before using, inspect the **Air Bike** for worn or loose components, and securely tighten or replace any worn or loose components prior to use.
12. Before using, always make sure the **SEAT** is securing tightened with the **Pull Pin Knob (55)**.
13. Each user should adjust the seat per instructions on page 12.
14. Do not attempt to adjust the seat while you are on the
15. Consult your physician before using this product. If you feel faint, dizzy, or experience pain during use, stop immediately and consult with your physician.
16. Choose the intensity that fits your strength and flexibility level. Know your body's limits and use this product within them. Use common sense when using this product.
17. Do not wear loose or dangling clothing while using the **Air Bike**.
18. Never exercise in bare feet or socks; always wear proper footwear such as running, walking, or cross training shoes that fit well, provide foot support, and feature non-skid rubber soles.
19. Be careful to maintain your balance while using, mounting, dismounting, or assembling the **Air Bike**, loss of balance may result in a fall and serious bodily injury.
20. The **Air Bike** should not be used by persons weighing over 350 pounds.
21. The **Air Bike** should be used by only one person at a time.
22. The **Air Bike** is for consumer use only. It is not for use in public or semipublic facilities.

## BEFORE YOU BEGIN

Thank you for choosing the **Air Bike**. We take great pride in this quality product and hope it will provide many hours of quality exercise to make you feel better, look better, and enjoy life to its fullest.

It's a proven fact that a regular exercise program can improve your physical and mental health. Too often, our busy lifestyles limit our time and opportunity to exercise. The **Air Bike** convenient and simple method to begin your journey of getting your body in shape and achieving a happier and healthier lifestyle.

Before reading further, please review the drawing below and familiarize yourself with the parts that are labeled. Locate the serial decal on the product and write the serial number on the cover of the manual in the space provided. See the next page for an image of the serial decal. Model number and serial number are required when

calling for assistance.

Read this manual carefully before using the **Air Bike**.

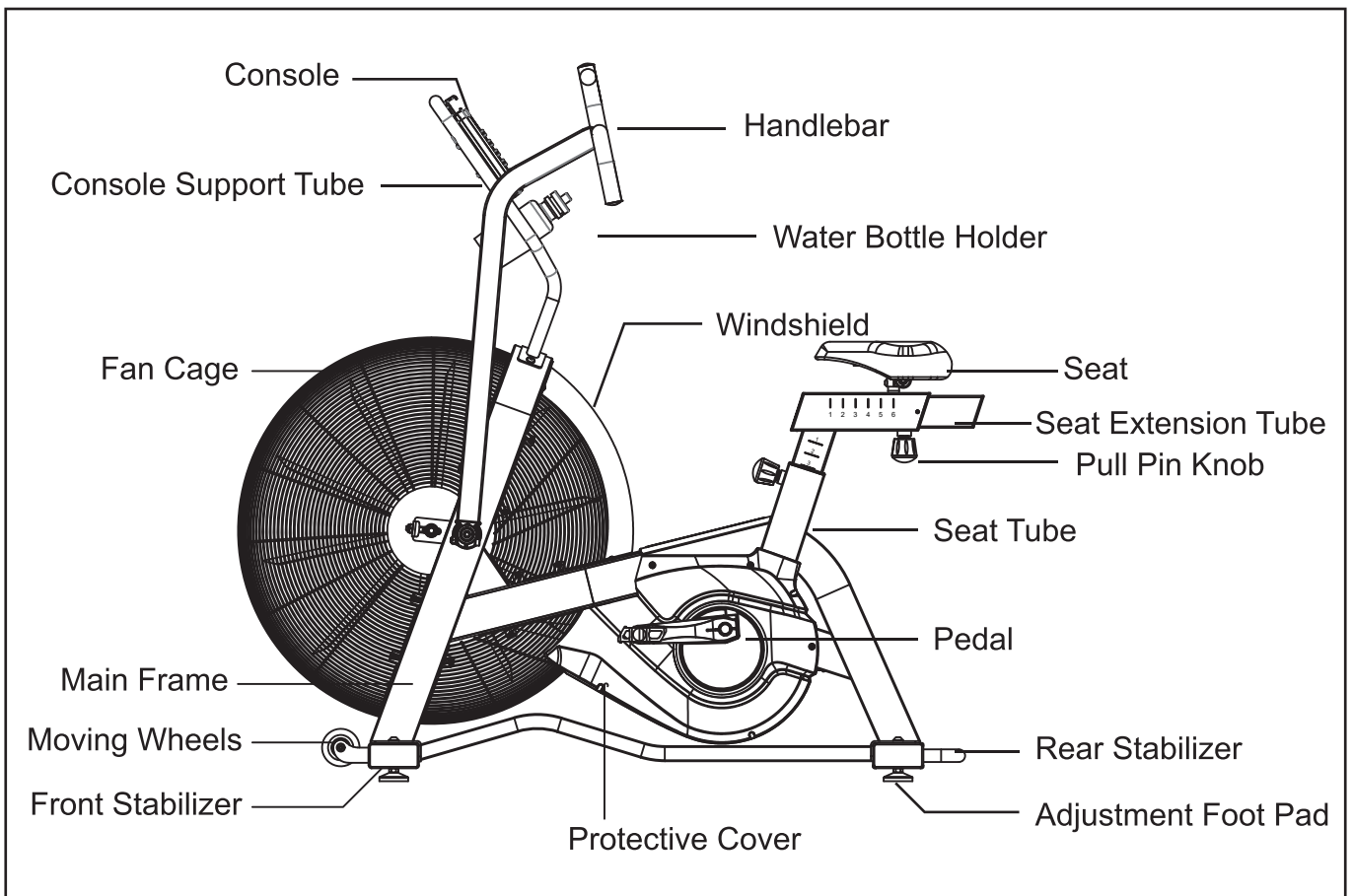

### THE FOLLOWING TOOLS ARE INCLUDED FOR ASSEMBLY:

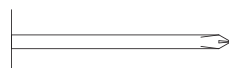
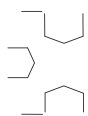

Wrench 13/15/17mm

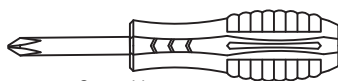

Screwdriver



Allen Wrench 5mm



Allen Wrench 6mm



Allen Wrench 8mm

## EQUIPMENT WARNING, CAUTION & NOTICE LABELS

This chart is provided to help identify the warning, caution, and notice labels on the Air Bike. Please take a moment to familiarize yourself with all of the warning, caution, and notice labels.

### CAUTION LABEL









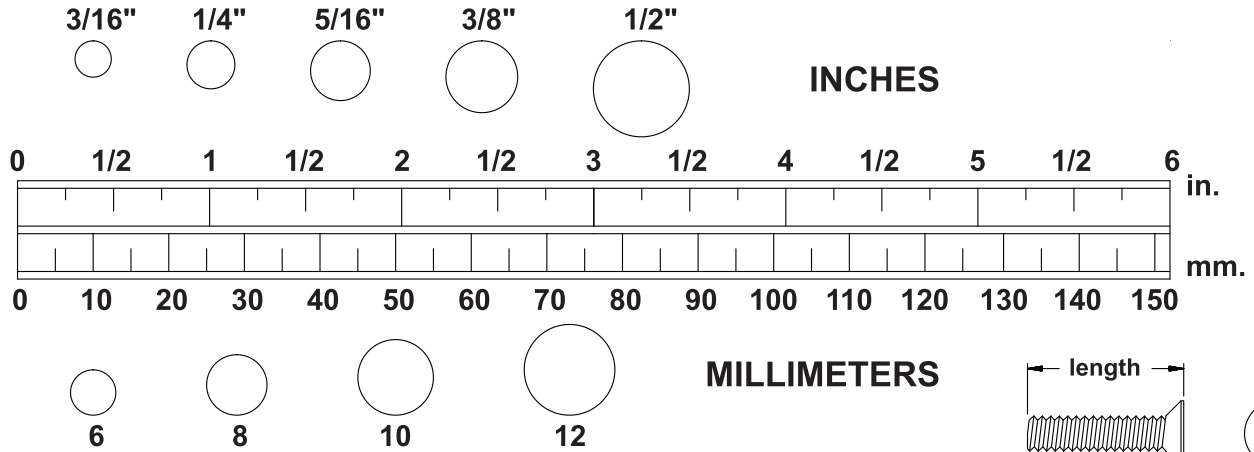

# HARDWARE IDENTIFICATION CHART

This chart is provided to help identify the fasteners used in the assembly process. Place the washers or the ends of the bolts or screws on the circles to check for the correct diameter. Use the small scale to check the length of the bolts and screws.

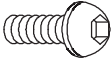
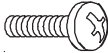
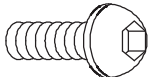

**NOTICE:** The length of all bolts and screws, except those with flat heads, is measured from below the head to the end of the bolt or screw. Flat head bolts and screws are measured from the top of the head to the end of the bolt or screw.

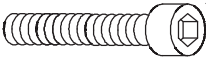
After unpacking the unit, open the hardware bag and make sure that you have all the following fasteners. Some fasteners may be already attached to the parts.

	Part Number and Description	Qty
	76 Hex Nut M8x1.25mm	4
	91 Spring Washer M8	4
	27 Flat Washer M8	6
	89 Truss Head Cap Screw M8x15mm	2
	87 Phillips Pan Head Screw M5x12mm	4
	96 Truss Head Cap Screw M10x1.5x15mm	4
	97 Flat Washer M10	4
	75 Socket Head Cap Screw M8x50mm	4
	94 Step Bolt 1/2"x133mm	2

## ASSEMBLY INSTRUCTIONS

Place all parts from the box in a cleared area and position them on the floor in front of you. Remove all packing materials from your area and place them back into the box. Do not dispose of the packing materials until assembly is completed. Read each step carefully before beginning.

**Some product parts are fit tested at the factory to ensure proper fit and alignment. Marks in the paint may be noticeable, but are not an indication of damage.**

**NOTE:** There are some packing parts attached on the Air Bike. Please follow the steps below to remove them before any assembly. These parts are only for packing, do not dispose of the packing materials until assembly is completed.

### STEP 1

1. Attach the Rear Stabilizer (69) to the Main Frame (1) by using:  
2PCs of Truss Head Cap Screw M10x1.5x15mm (96) and 2PCs Flat Washer M10 (97).
2. Attach the Front Stabilizer (62) to the Main Frame (1) by using:  
2PCs of Truss Head Cap Screw M10x1.5x15mm (96) and 2PCs Flat Washer M10 (97).

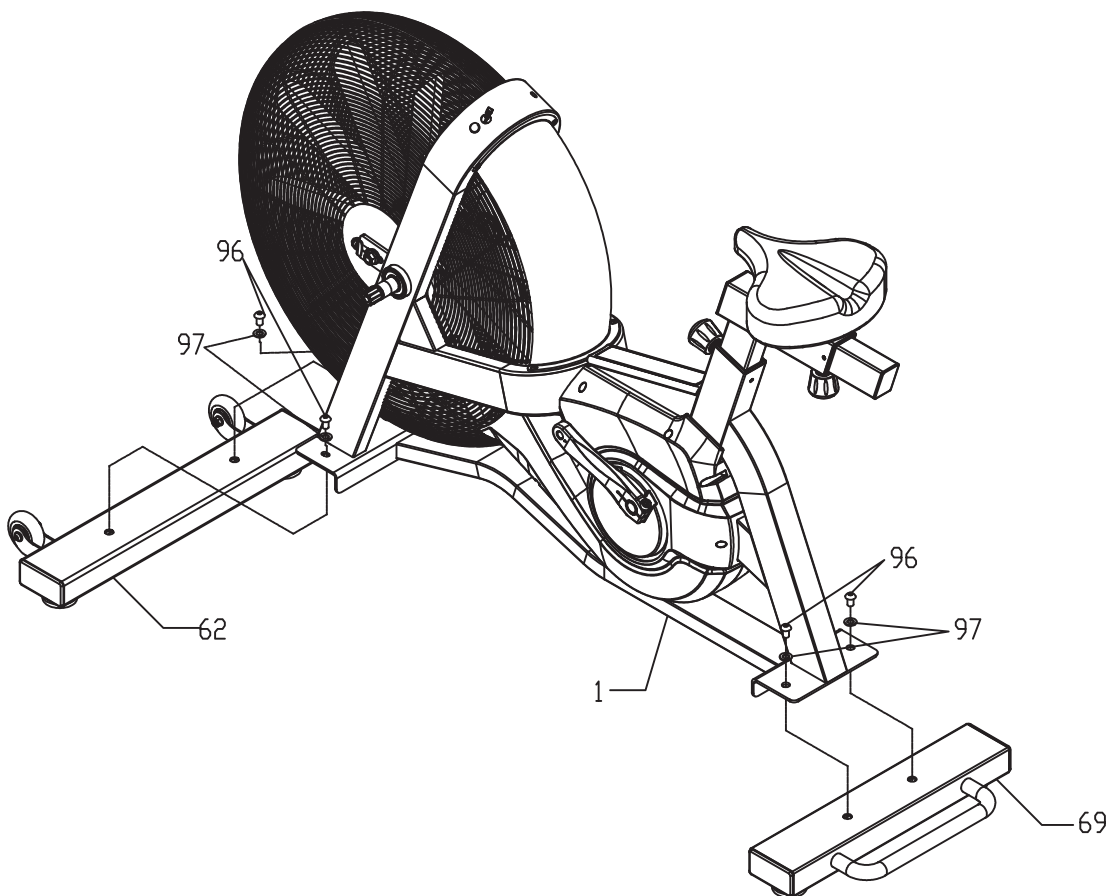

## ASSEMBLY INSTRUCTIONS

### STEP 2

1. Tighten the Left Pedal (14) by rotating it into Left Crank (12) counterclockwise.
2. Tighten the Right Pedal (15) by rotating it into Right Crank (13) clockwise.
3. Attach the Console Support Tube (85) to the Main Frame (1) by using:  
2PCs Truss Head Cap Screw M8x15mm (89) and 2PCs Flat Washer M8 (27).

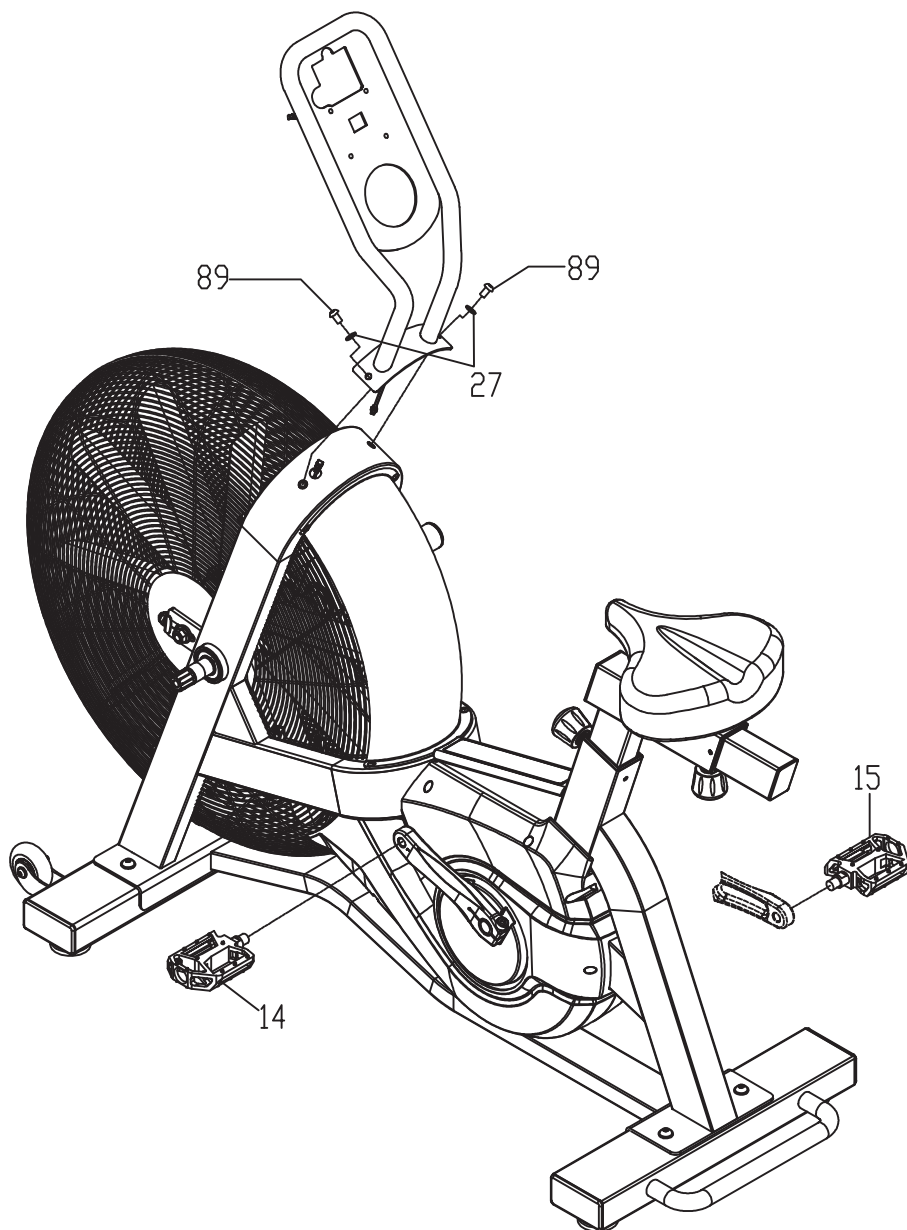

## ASSEMBLY INSTRUCTIONS

### STEP 3

1. Connect the Sensor Wire (88) to the Console (84), and attach the Console (84) to the Console Support Tube (85) by using: 4 PC Phillips Pan Head Screw M5x12mm (87).
2. Assemble the Water Bottle Holder (83) to the Console Support Tube (85). Then put the Water Bottle (82) into the Water Bottle Holder (83).

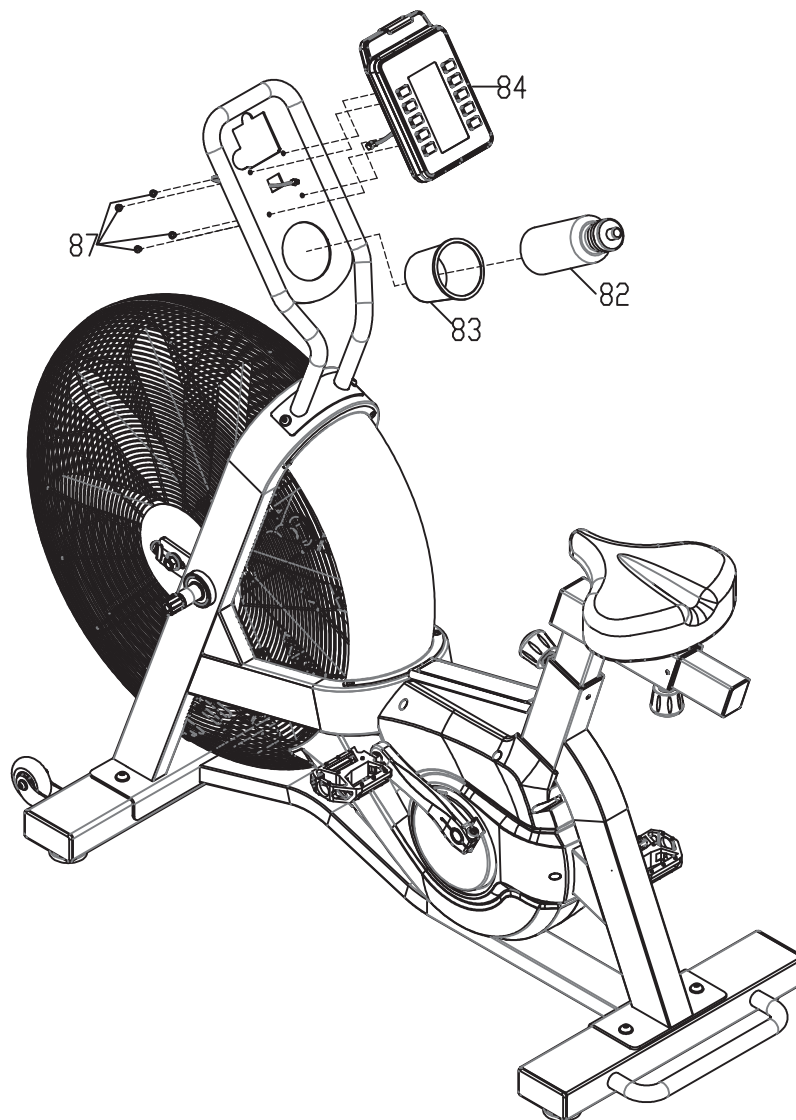

## ASSEMBLY INSTRUCTIONS

### STEP 4

1. Attach Left Handlebar (90) to the Left Linkage (29) by using: 2PCs of Head Cap Screw M8\*50mm (75), Flat Washer M8 (27), 2PCs of Spring Washer M8 (91) and 2PCs of Hex Nut M8 (76) in sequence.
2. Attach Right Handlebar (95) to the Right Linkage (29) by using: 2PCs Head Cap Screw M8\*50mm (75), Flat Washer M8 (27), 25Pcs of Spring Washer M8 (91) and 2PCs of Hex Nut M8 (76) in sequence.
3. Pass through the Footrest Ø38 (92) with Step Bolt 1/2"x133mm (94), and tighten on the Short Linkage (29).

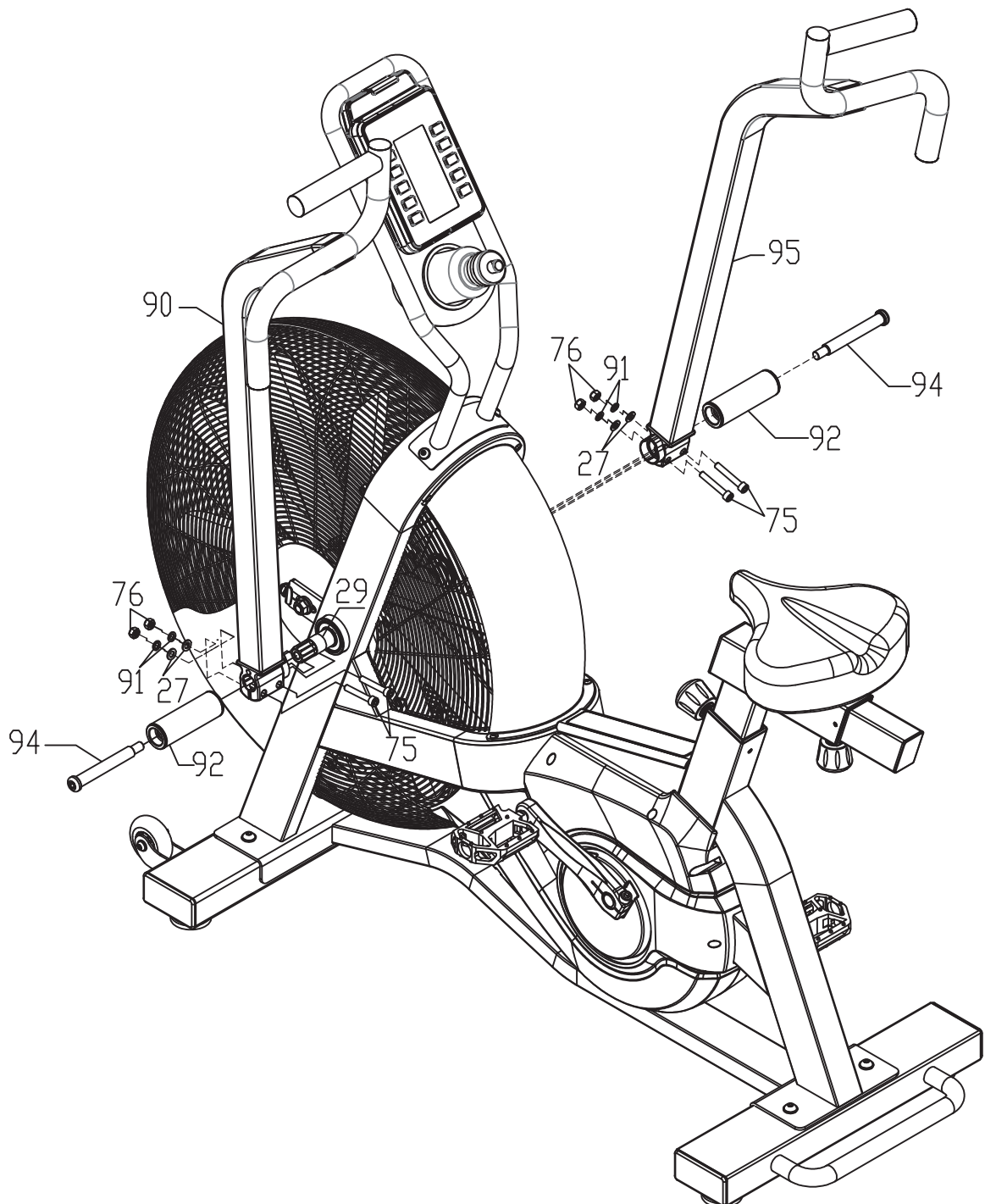

## SET UP INSTRUCTIONS

Place the Air Bike in the area where it will be used. It is recommended that the Air Bike be placed on an equipment mat. Make sure that adequate space is available for access to and passage around the Air Bike.

**LEVELING:** Adjust the Stand (63) under the Rear Stabilizer (69) so that the Air Bike sits on the floor without rocking. Refer to the instructions below.

**MOVING:** The Air Bike has a pair of Moving Wheels (66) on the Front Stabilizer (62). Lift up from the handle at the back of the Air Bike to move.

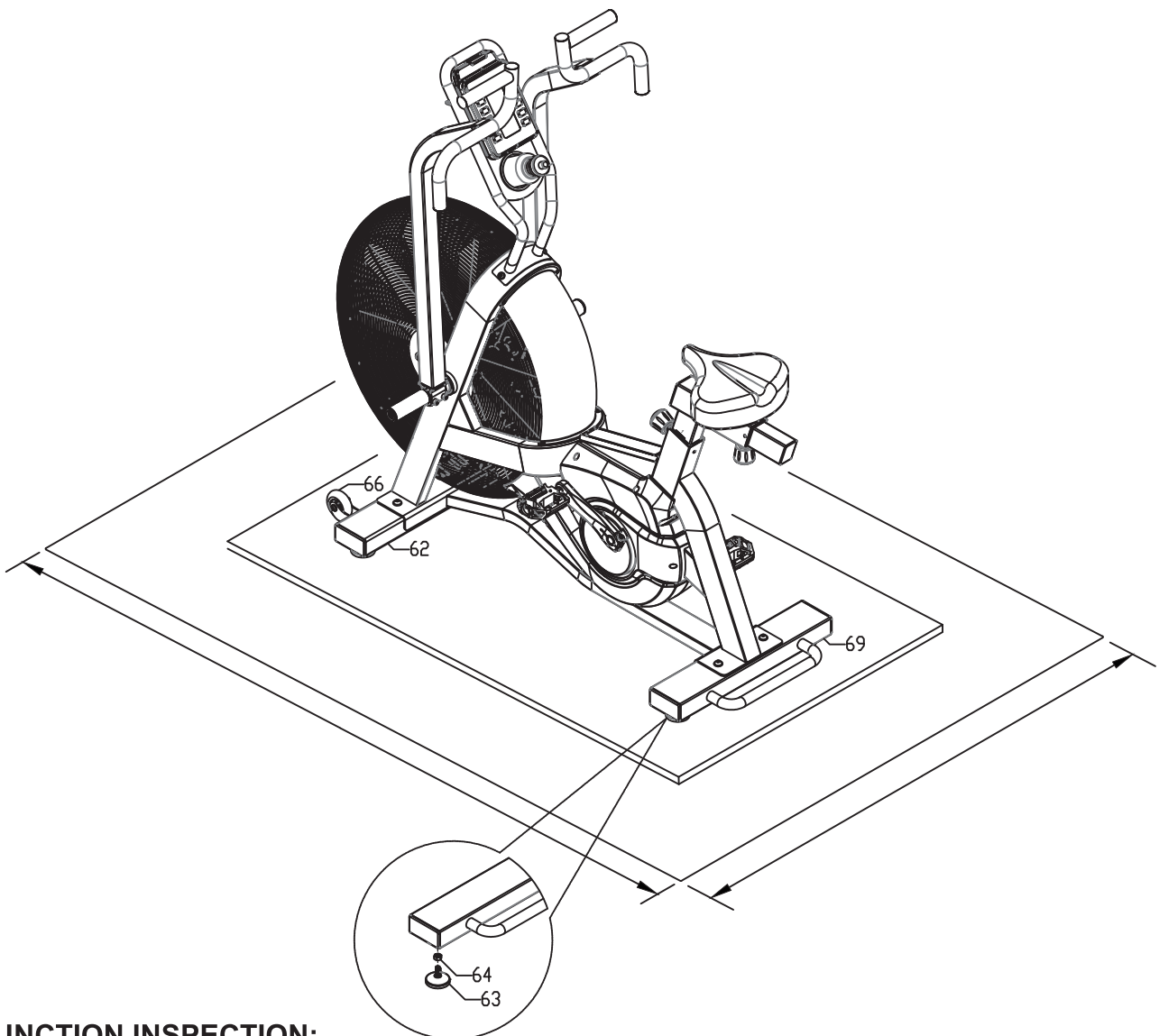

### FUNCTION INSPECTION:

Visually inspect the Air Bike to verify that assembly is as shown in the above illustration. Check the function of the Air Bike by turning the crank slowly through one complete revolution to verify that the drive train functions properly.

**CAUTION:** Locate and read the Caution Labels on the Air Bike.  
Make sure that all users read the Caution Labels before using.



## 1、COMPUTER INSTRUCTIONS：

1、After installing battery (POWER ON), LCD will display all data for 2 seconds (Figure 1), and beep twice within 0.5s to enter the IDLE mode.

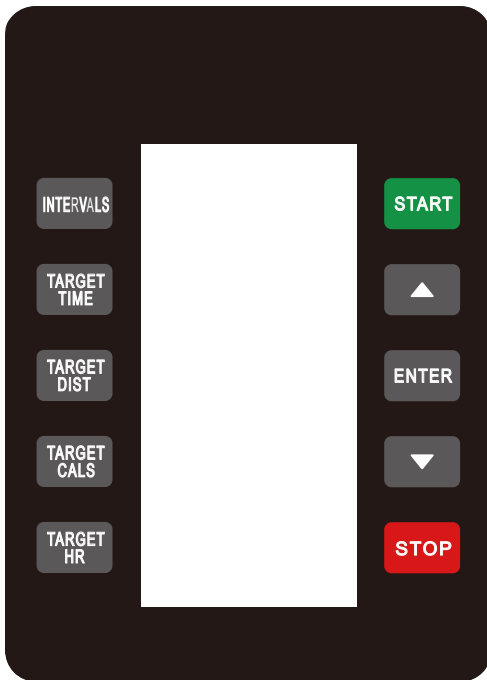

(Figure 1)

## 2、QUICK START：

A、In IDLE mode, if RPM signal is higher than 15, the monitor will beeps once and enter “QUICK START”. Or pressing START button to enter “QUICK START”.

B、When heartbeat is imputing, the “HEART RATE” sign will last. The heartbeat sign “♥” will also flash and display the instant heartbeat data (Figure 2); when there is no heartbeat imputing, “HEART RATE” sign will not display. “NO SIGNAL” and heartbeat sign “♥” will still display, but the Heartbeat will display "---"

C、When doing the workout, all key are invalid except “START” , “STOP” , “ENTER” .

D、Press “START” to enter the Pause Mode while doing the workout, the monitor will only display TIME, DISTANCE, CALORIES (Figure 3). Displaying 0.5 second and un-display 0.5 second.

If there is continuous RPM signal imputing, the monitor will has Beep sound for twice last for 5 minutes and enter IDLE mode.

If there is no RPM signal imputing for 5 minutes, the monitor will enter sleep mode.

In pause mode, press ENTER KEY for 3 seconds to switch on /off the Bluetooth function. Press START to continue the exercise and STOP to end the exercise.

E、While exercising, if there is no button pressing and RPM signal, but there is heartbeat signal

inputting for 5 minutes, the monitor will end the exercise.

F · While the workout finished, monitor display: TIME(display exercise time), DISTANCE(display exercise distance), CALORIES(display exercise calories burned) (Figure 4)

G · When the workout is finished and there is no RPM signal input for 5 minutes, the monitor will enter the sleep mode.

If RPM signal data is higher than 15 and last for 6 seconds, the computer will enter “QUICK START”.

If RPM signal data is less than 15 and last for 5 minutes, the monitor will BIBI and enter IDLE MODE.

H · When workout finished, if you have press any PROGRAM button to do the related action, press START to enter QUICK START, press STOP button to enter IDLE MODE after BIBI sound.



(Figure 2)



(Figure 3)



(Figure 4)

### 3 · INTERVAL 20-10 :

A · In IDLE MODE, press INTERVALS once and the sign will last. 20/10 sign will display 0.5 second and un-display 0.5second. Press ENTER to confirm the selection and enter the mode. TOTAL TIME display 04:00 and the loops display 0/8 (Figure 5). Press START to start the workout directly.

B · Press ENTER or START key to launch this function.

C · After counting down for 3 seconds, WORK will start counting down 20 seconds. TOTAL TIME will start counting and TIME will also start the 4 minutes counting down. SPEED · WATTS ·

RPM、DISTANCE、CALORIES start counting according to the data and the loop will shows 1/8.(Figure 6)



(Figure 5)



(Figure 6)

**4、INTERVAL 10-20：**

A、In IDLE MODE, press INTERVALS twice and the sign will last. 10/20 sign will display 0.5 second and un-display 0.5second. Press ENTER to confirm the selection and enter the mode. TOTAL TIME display 04:00 and the loops display 0/8(Figure 7). Press START to start the workout directly.

B、Press ENTER or START key to launch this function

C、After counting down for 3 seconds, WORK will start counting down 20 seconds. TOTAL TIME will start counting and TIME will also start the 4 minutes counting down. SPEED、WATTS、RPM、DISTANCE、CALORIES start counting according to the data and the loop will shows 1/8(Figure 8).



(Figure 7)

(Figure 8)

## 5 · INTERVAL CUSTOM :

- A · In IDLE MODE, press INTERVALS third and the sign will last. CUSTOM sign will display 0.5 second and un-display 0.5second (Figure 9). Press ENTER to confirm the selection and enter the mode. TOTAL TIME display the default time 06:40 and the loops display 0/8. The setting range for loop is 1~99. Press START to start the workout with current setting.
- B · In CUSTOM setting mode: Press UP or DOWN to adjust the number of loops and TOTAL TIME will be changed accordingly. Press ENTER to enter into next setting( WORK→REST→CYCLES→WORK). Press STOP to enter IDLE MODE and START to enter WORKOUT MODE.
- C · After the LOOP setting is done, press ENTER will enter the time setting of WORK and the loop's data will keep displaying. The default time of WORK is 0:30 (Figure 10), press UP/DOWN to adjust the time of WORK. The range of WORK time setting is 0:01~9:59 , TOTAL TIME will changed according to WORK time setting. While setting, press ENTER to confirm and enter the next setting( REST→LOOP→WORK→REST).
- D · After WORK time setting has been settled, press ENTER to enter the RESET time setting, the LOOP's display will keep displaying as 0/N. The default time for REST is 0:20 (Figure 11), press UP/ DOWN to adjust the time of RESET and the setting range is 0:01~9:59. TOTAL TIME will changed according to RESET time setting. While setting, press ENTER to confirm and enter the next setting( LOOP→WORK→REST→LOOP)



(Figure 9)



(Figure 10)



(Figure 11)

## 6、TARGET TIME：

- A、In IDLE MODE, press TARGET TIME to enter the setting mode. TARGETS and TIME signs will keep displaying and flashing the default time setting 10:00 (Figure 11). Press START to start the workout directly.
- B、In the setting mode of TARGET TIME, press UP/DOWN to adjust the time and the time setting range of TARGET TIME is 1:00~99:00.



(Figure 11)

## 9、TARGET DISTANCE

- A、In IDLE MODE, press TARGET DIST KEY to enter the setting mode. TARGETS and DISTANCE signs will keep displaying and flashing the default distance setting 3.00 (Figure 12). Press START to start the workout directly.
- B、In the setting mode of TARGET DISTANCE, press UP/DOWN to adjust the distance and the time setting range of TARGET DISTANCE is 0.50~99.00.



(Figure 12)



## 10 · TARGET CALORIES :

- A · In IDLE MODE, press TARGET CALS KEY to enter the setting mode. TARGETS and CALORIES signs will keep displaying and flashing the default calories setting 20 cal (Figure 13). Press START to start the workout directly.
- B · In the setting mode of TARGET CALORIES, press UP/DOWN to adjust the CALORIES and the time setting range of TARGET CALORIES is 1~999.



(Figure 13)

## 11 · TARGET heart rate 80% :

- A · In IDLE MODE, press TARGET HR button once, TARGETS and HEART RATE sign keep displaying. Press ENTER button to confirm the selection and enter the setting mode of TARGET heart rate 80%. TARGETS, HEART RATE and 80% sign will keep displaying. The window of 80% display default age which convert by the heart rate data of 80%. AGE sign flashing and displaying preset age 24 (Figure 14). Press START to start the workout directly.
- B · In the setting mode of TARGET heart rate 80%, press UP/DOWN to adjust the AGE and the heart rate of 80% will adjust accordingly. The range of AGE setting is 10~120.
- F · While doing the workout, if the heart rate is less than the heart rate data of 80% about 5, the monitor will flash and show the sign of  (Figure 15).
- G · While doing the workout, if the heart rate is higher than the heart rate data of 80% about 5, the monitor will flash and show the sign of  (Figure 16).
- H · While doing the workout, if the heart rate maintain the heart rate data of 80% within 5, the monitor will display the current data (Figure 17).





(Figure 14)



(Figure 15)



(Figure 16)





(Figure 17)

## 12、TARGET heart rate 65%：

A、In IDLE MODE, press TARGET HR KEY twice, TARGETS and HEART RATE sign keep displaying. Press ENTER button to confirm the selection and enter the setting mode of TARGET heart rate 65%. TARGETS, HEART RATE and 65% sign will keep displaying. The window of 65% display default age which convert by the heart rate data of 65%. AGE sign flashing and displaying preset age 24(Figure 18). Press START to start the workout directly.

B、In the setting mode of TARGET heart rate 65%, press UP/DOWN to adjust the AGE and the heart rate of 65% will adjust accordingly. The range of AGE setting is 10~120.

F、While doing the workout, if the heart rate is less than the heart rate data of 65% about 5, the monitor will flash and show the sign of  (Figure 19).

G、While doing the workout, if the heart rate is higher than the heart rate data of 65% about 5, the monitor will flash and show the sign of  (Figure 20).

H、While doing the workout, if the heart rate maintain the heart rate data of 80% within 5, the monitor will display the current data(Figure 21).



(Figure 18)

(Figure 19)

(Figure 20)

(Figure 21)

## 2、Special Function Instruction：

### KM/MI Setting

A、In IDLE MODE: Press **UP**、**DOWN** at the same time for 3 seconds and set up KM /MI directly. The monitor will display the unit after setting changed. SPEED and DISTANCE sign will last. KM、KMPH (Figure 22) or MI、MPH (Figure 23) will flash for 3 seconds and enter the IDLE MODE.



(Figure 22)



(Figure 23)

B、The monitor doesn't have memory function. So, when the battery been removed and put it back again, the monitor will return to the default setting.

### Bluetooth Function

A、In IDLE MODE, WORKOUT MODE OR PAUSE MODE, press ENTER for 3 seconds to switch on/off Bluetooth function.

B、After the Bluetooth function is on, the APP can be connected to the monitor.

C、After the console been connected to the APP, the display will turn off but shows the Bluetooth sign and keeps flashing.

D、The Bluetooth can be connected to APP and chest belt at the same time.

## OPERATIONAL INSTRUCTIONS

### SEAT HEIGHT ADJUSTMENT

Proper seat height is important for efficient exercise. To determine proper seat height, sit on the bike and center the ball of your foot on the pedal in the down position. Your leg should be slightly bent and relaxed as shown. If your leg is too straight or your foot cannot touch the pedal, you need to lower the seat. If your leg is bent too much you will need to raise the seat.

Unlock the Pull Pin Knob (55) by turning it counterclockwise. Pull out the Pull Pin Knob (55) to adjust Seat Tube (67) to a desired height.

NOTE: Do not pull the seat post out too far, the maximum is indicated on the seat post.

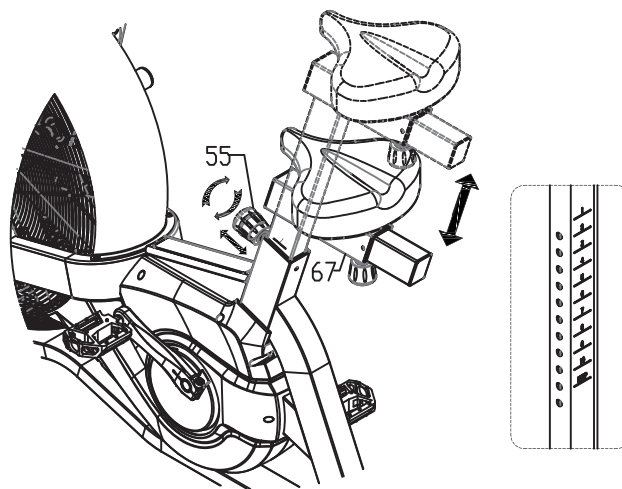

### FORWARD/AFT POSITION OF SEAT

Unlock the Pull Pin Knob (55) by turning it counterclockwise. Pull out the Pull Pin Knob (55) to adjust the Seat Extension Tube (71) to a desired position.

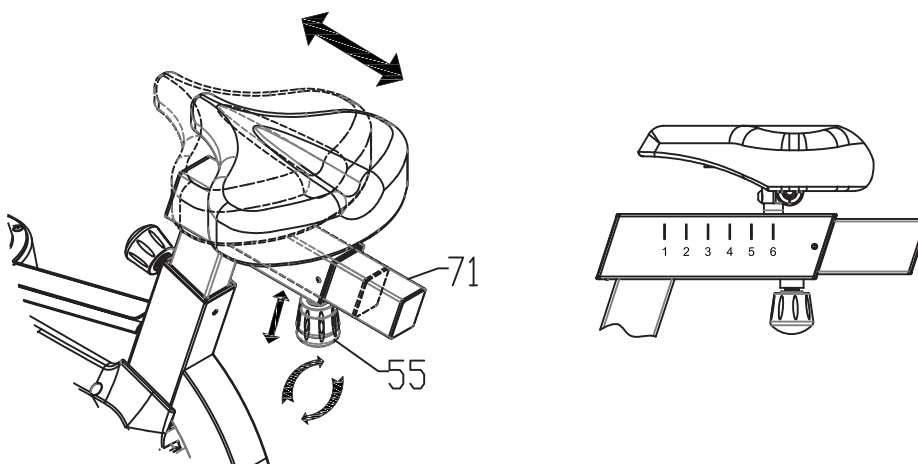

# PRODUCT PARTS DRAWING

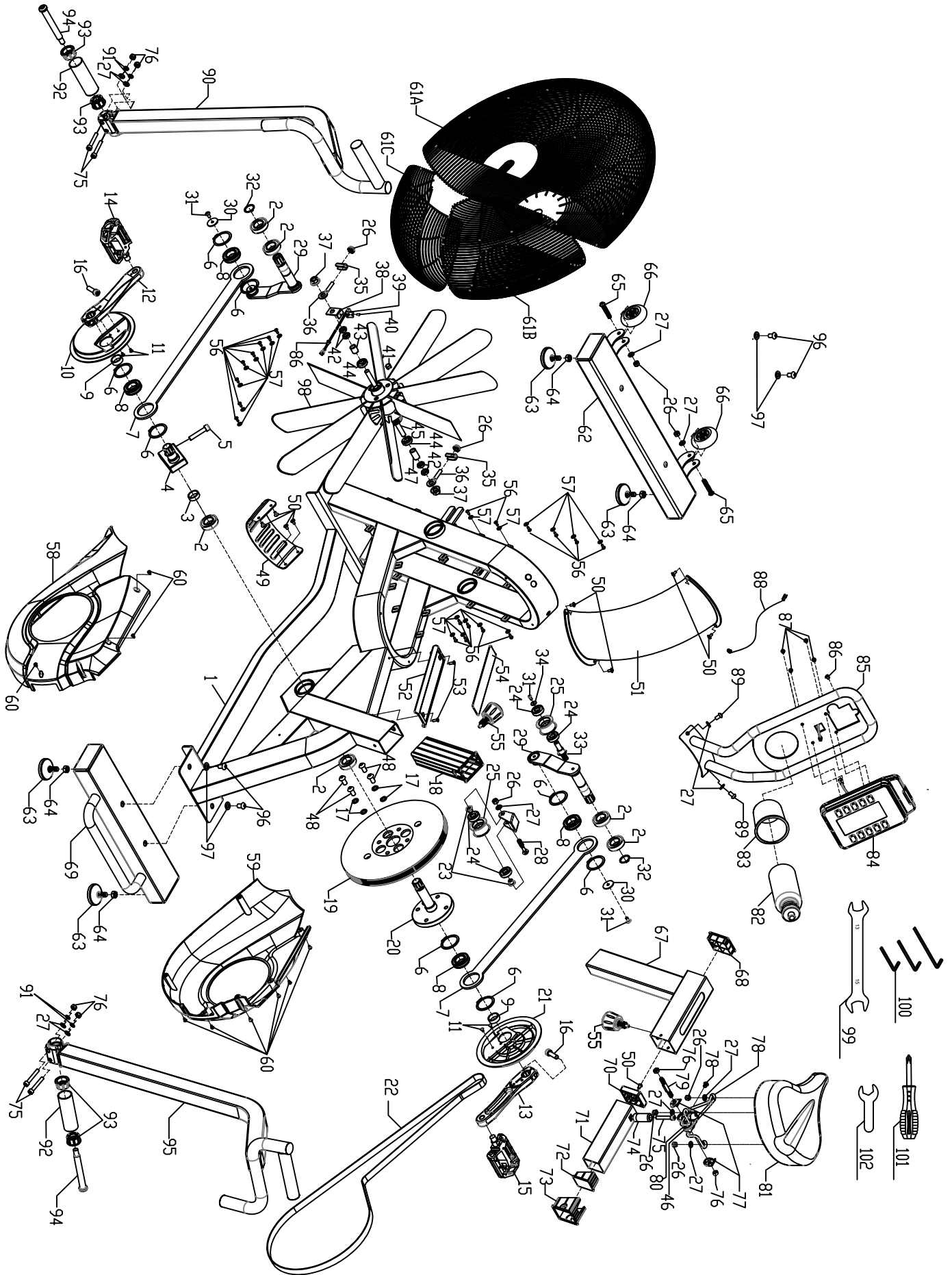

## PARTS LIST

PART#	PART NAME	QTY
1	Main Frame	1
2	Bearing 6005z	6
3	Spacer Ø30*Ø25.2*9.8mm	1
4	Square Crank	1
5	Socket Head Cap Screw M10x1.5x50mm	1
6	Circlips Ø47mm	8
7	Left / Right Linkage	2
8	Bearing 6005z for circlip	4
9	Spacer Ø30*Ø25.2*10.5mm	2
10	Left Disc	1
11	Phillips Pan Head Screw M4x10mm	4
12	Left Crank	1
13	Right Crank	1
14	Left Pedal	1
15	Right Pedal	1
16	Socket Head Cap Screw M10x1.25x35mm	2
17	Spring Washer M10	4
18	Hollow Seat Tube Set	1
19	Belt Pulley	1
20	Cranksaft	1
21	Right Disc	1
22	Belt	1
23	Idle Gear Ø18*Ø8.1*12mm	2
24	Bearing 6201z	4
25	Idler Pulley Ø48*25mm	2
26	Hex Nut M8	8
27	Flat Washer Φ9*Φ16mm	12
28	Carriage Screw M8*45mm	1
29	Left / Right Short Linkage	2
30	Flat Washer Φ6.2*Φ30mm	2
31	Truss Head Cap Screw M6x12mm	3
32	Circlips Ø25mm	2
33	Idler Pulley Holder	1
34	Flat Washer Φ6.2*Φ16mm	1
35	Buckle	2
36	Cat Eye Screw M8x40mm	2
37	Flange Nut M12x1.25mm	2
38	Sensor Clip Holder	1
39	Sensor Clip	1
40	Phillips Pan Head Self-Tapping Screw ST3.5x10mm	1
41	Magnet	1
42	Hex Nut M12x1.25mm	4
43	Sleeve Ø15*Ø13*15.5mm	1
44	Bearing 6001Z	2
45	Fan Axis	1
46	Inner Beam Calipers	2
47	Sleeve Ø15*Ø13*27mm	1
48	Truss Head Cap Screw M10x20mm	4
49	Lower Protective Cover	1

## PARTS LIST

PART#	PART NAME	QTY
50	Phillips Pan Head Screw M5x10mm	9
51	Windshield	1
52	Pedal Tray	1
53	Phillips Flat Head Screw M5x10mm	2
54	Pedal	1
55	Pull Pin Knob	2
56	Phillips Pan Head Self-Tapping Screw ST4.2*15mm	20
57	Flat Washer Ø5.3*Ø15mm	20
58	Left Protective Cover	1
59	Right Protective Cover	1
60	Phillips Pan Head Self-Tapping Screw ST4.0*12	9
61A	Front Fan Cage	1
61B	Upper Fan Cage	1
61C	Lower Fan Cage	1
62	Front Stabilizer	1
63	Adjustment Foot Pad	4
64	Hex Nut M10x1.5mm	4
65	Truss Head Cap Screw M8x45mm	2
66	Moving Wheel	2
67	Seat Tube	1
68	Square Inner Pulg	1
69	Rear Stabilizer	1
70	Square Outer Plug	1
71	Seat Extension Tube	1
72	Square Inner Pulg 38.1x63.5mm	1
73	Hollow Plug	1
74	Seat Mounting Post	1
75	Socket Head Cap Screw M8x50mm	5
76	Hex Nut M8	6
77	Outer Beam Calipers	2
78	Truss Head Cap Screw M8x7mm	1
79	Screw for Beam Calipers (M8)	1
80	Seat Mounting Post Holder	1
81	Seat	1
82	Water Bottle	1
83	Water Bottle Holder	1
84	Console	1
85	Console Support Tube	1
86	Wire Plug Ø12	2
87	Phillips Pan Head Screw M5x12mm	4
88	Sensor Wire	1
89	Truss Head Cap Screw M8x15mm	2
90	Left Handlebar	1
91	Spring Washer M8	4
92	Footrest Ø38	2
93	Round Plug Ø38	4
94	Step Bolt 1/2"x133mm	2
95	Right Handlebar	1
96	Truss Head Cap Screw M10x1.5x15mm	4



## ***PARTS LIST***

<b>PART#</b>	<b>PART NAME</b>	<b>QTY</b>
97	Flat Washer M10	4
98	Fan Blades Set	1
99	Screwdriver	1
100	Open Wrench 13-15-17	1
101	Allen Wrench 5mm / 6mm / 8mm	1+1+1



GARLANDO SPA  
Via Regione Piemonte, 32 - Zona Industriale D1  
15068 - Pozzolo Formigaro (AL) - Italy  
[www.toorx.it](http://www.toorx.it) - [info@toorx.it](mailto:info@toorx.it)